



# TCG 1000S



## TIME CODE GENERATOR User Manual

2<sup>nd</sup> Edition: December 2004

---

## TABLE OF CONTENTS

1. INTRODUCTION	3
2. INSTALLATION	4
2.1 Packing list	4
2.2 Mounting	4
2.3 Output Signals	4
2.4 Connections	5
3. OPERATION	6
3.1 Front Panel LEDs	6
4. SPECIFICATIONS	8
4.1 Input / Output – electrical / physical	8
4.2 Input/Output - Functions & Applications	9
4.3 Indicators & Display Unit	10
4.4 Power Requirements	10
4.5 Isolation & Protection	10
4.6 Dimensions	10
4.7 Identification	10
5. FACTORY HARDWARE OPTIONS	11
5.1 Power Supply Options – Opt. 2M, Opt. 2H	11
5.2 Lightning Protection Kit – Opt. 4	11
6. TCG1000 CONFIGURATION SOFTWARE	12
6.1 General Options	12
6.2 Local Time Settings	13
6.3 Programmable Outputs	14
6.4 IRIG-B Options	15
6.5 Serial Port Output Options	16
6.6 GPS Setup	20
APPENDIX A – ANTENNA DETAILS	22
A.1 Antenna Cable Specification	22
A.2 Antenna Specification	23
A.3 Antenna Mounting	24
A.4 Antenna Lightning Protection Kit	25
WARRANTY STATEMENT	29

## 1. INTRODUCTION

The TCG 1000S Time Code Generator / Clocks produce time code signals, serial strings and pulses primarily for use in synchronising industrial control and SCADA equipment.

They are ideally suited to providing time synchronisation to many different devices, such as Remote telemetry Units (RTUs), Protection Relays and other Intelligent Electronic Devices (IEDs) typically deployed in electrical sub-stations and industrial control installations.

The unit has one serial port, programmable with a wide range of time code signals and pulse configurations. The unit also has a change over contacts sync status relay to provide positive indication when the unit is 'in sync' / 'out of sync'.

The front panel has 2 LED indicators providing "at a glance" status information.



**Fig 1. TCG 1000 Front Panel**

The timing optimised Receiver / Antenna system employed in TCG01 provides time information from the GPS satellite constellation. Dynamic T-RAIM processing is used to eliminate any aberrant satellite signals from the timing solution. The result is timing precision on the RS232 output with accuracy similar to that normally seen only in laboratory instruments.

However, unlike laboratory instruments, TCG 1000 is ideally suited for service in hostile electromagnetic environments such as sub-stations and electrical switchyards. The internal electronics are isolated from the outside world.

The TCG 1000 unit occupies less than half the width of a 1U rack space. It is supplied complete with all hardware and software required for installation, including rack-mount kit, connectors, 15m lead-in antenna cable, and antenna.

## 2. INSTALLATION

### 2.1 Packing list

Each TCG 1000 kit is shipped with the following:

- TCG 1000 Time Code Generator
- User Manual (this document)
- GPS Antenna (optimised for stationary applications), with mounting bracket
- 15m of antenna lead-in cable (fitted with matching connectors)
- 19" Rack mounting Plate & fasteners
- Plug-in connectors (1 x 2way, 1x 3way miniature)
- RS232 Interface cable (9 pin male "D" connectors at both ends)
- Configuration Software

### 2.2 Mounting

The clock is designed to be mounted in a 19" rack, but may be used on a bench. The unit is attached to the rack mount plate via the four screws shipped installed in the four corners of the front panel.

**GPS Antenna:** Detailed antenna mounting instructions are contained in [Appendix A.3](#). The antenna should be located in a position with as clear a view of the sky as possible, over as wide an angle as possible.

The antenna should also be mounted in a "lightning-protected zone" as far as is possible. In practice, this means ensuring that there is at least one other earth-bonded structure located in the same rooftop area (e.g. another antenna, or a lightning rod) that reaches significantly higher than the top of the GPS antenna. The GPS Antenna should be mounted so that it lies within a 45-degree angle "skirt" from the top of the other earth-bonded structure. The GPS antenna mount itself should also be securely bonded directly to the building protection earth – and *not* connected via any of the other earthed structures.

A lightning protection kit is available for installation in the antenna lead-in cable for additional protection of the equipment. (See [section 5.2](#) p11 for details).

 **All TCG 1000 antenna installations should follow the guidelines above.**

### 2.3 Output Signals

Each TCG 1000 unit ships with a default signal configuration as below:

**Plug 4: (pin 1 and 5)** DCF77 output simulation– RS232 level pulses

**Plug 4: (pins 2,3 and 5)** RS232 level communications Tx and Rx

**Plug 7:** Sync Relay output (Change-Over contacts)

The default configuration can be field-modified using the configuration software shipped with the clock. See [section 6](#) p12 for details of the configuration software. By prior arrangement, different shipping defaults can be configured at the factory if required.

## 2.4 Connections

All connections to the unit are via the rear panel.



**Fig 2. TCG 1000S Rear panel**

**P1** Power is applied to the unit via this plug. Maximum power consumption is 5 watts. Despite the markings on P1, the polarity of the power connection is *not* important and the unit is fully isolated internally from the power source. A mating connector is supplied with the unit, suitable for wiring sized up to 1.5mm<sup>2</sup>.

**☛** *Check the option label on the unit base for power supply voltage ratings!!!*

**Ant** The antenna lead-in cable connects to the “Ant” connector located above the fuse. Care should be taken to ensure that the connector is not cross-threaded when attaching the antenna lead-in cable. The connector should be tightened firmly *by hand only*.

**P4** DB9 male connector providing a “DCE” serial port on pins 2, 3 and 5, plus a programmable output line on pin 1 (shares pin 5 for return). If the output signal on pin 1 is required for purposes other than time-syncing a direct-connected PC (“DTE”), an adapter unit will be required to “break-out” pins 1 and 5). Do *not* over-tighten the securing screws for the RS232 connector. The supplied cable features securing screws with finger-grips. There is no requirement for any tools to be used for this task!

**P7** Sync status relay contacts. When the clock is in sync, the “NO” and “C” terminals are connected. A mating connector is supplied (Wiring to 1mm<sup>2</sup>.)

### 3. OPERATION

Connect the antenna lead and the antenna (with a good view of the sky). Then connect the power source to **P1**.

☛ *Check the option label on the base for voltage requirements before switching on!*

The time required to achieve tracking and synchronisation (given a good “view” of the sky) will vary from just a few seconds to around 45 minutes in the worst case – such as reactivating a unit that was previously synchronised 1000’s of km away from the present position.

#### 3.1 Front Panel LEDs

The **GPS** LED shows the status of the GPS receiver, while the **SYN** LED shows the status of the time synchronisation to UTC reference time derived from the GPS satellites.

☛ By default, all outputs become active within a few seconds of initial power-up even when the unit is *not* synced to GPS satellite time! Output time data is not precise until the unit is synced to the GPS satellites!

#### Warning Status Indications – (SYN LED not illuminated)

The sync relay is deactivated (“C” connected to NC”). The accuracy of the clock outputs is not guaranteed correct for syncing purposes! The **GPS** LED shows warning states as follows:

##### Warning Status 1:      ■■■■ ■■■■ ■■■■

**GPS** LED flashing rapidly (at about 4 flashes per second): Either the antenna is not connected, or it is short or open-circuited. When the antenna is operating correctly, this sequence will not be seen.

##### Warning Status 2:      ■■    ■■    ■■

**GPS** LED flashing with a two flash pattern, repeating each second: The unit is searching the sky for satellites to begin the sync process.

#### OK Status Conditions – (SYN LED illuminated continuously)

The sync relay output is activated, giving both visual and electrical indications that the system is operating normally. All of the output time data is then accurate and usable for sync purposes. There are two normal operating states:

##### OK Status 1:                    ——— ——— ———

The **GPS** LED flashes with a single flash each second, with the “ON” period much longer than the “OFF” period. The clock shows this status after first obtaining satellite sync. The long “ON” cadence shows that satellite tracking is operating. (The 2<sup>nd</sup> status character on the LCD display shows the number of satellites being tracked) Accuracy on all outputs is typically within 1microSec of UTC in this state. As soon as 4 or more satellites are being tracked, the unit starts a site survey. The survey determines the precise position of the antenna (Latitude, longitude and Height) by taking the average result of 10,000 position solutions based on data from 4 or more tracked satellites. A new position solution is calculated each second, so under “clear sky view” circumstances (at least 4 satellites tracked almost immediately from switch-on) the site survey will take about 3 hours. On completion of the survey, TCG 1000 “freezes” the position and proceeds to the most accurate operating state, OK state 2 below.

**OK Status 2:**

The **GPS** LED flashes a one-second “heart-beat” as above, but with a shorter “ON” period than “OFF”. The 3<sup>rd</sup> status char on the LCD display shows **P**. In this mode, the embedded GPS receiver operates in “Position-Hold” mode and devotes all resources to resolving the most accurate time solution. Using T-RAIM processing, this mode yields the best steady-state timing accuracy that the clock is capable of viz: leading edge of output signals to within 60nanoSec, and typically to within 40nanoSec, of UTC time. (Provided that the antenna feed delay is compensated correctly – this is automatic when the clock is installed using the 30M-antenna cable normally supplied with the kit.

## 4. SPECIFICATIONS

### 4.1 Input / Output – electrical / physical

#### Antenna input “ant”: (SMA jack)

The antenna input provides an interface for an external active antenna via low-loss coaxial cable, 50Ω impedance. 5V DC is supplied (maximum current of 50mA) to power an active antenna. The total combined gain of the antenna system (antenna plus cable and connectors) should fall in the range of 10 to 35 dB, the optimum being 22dB.

The TCG 1000 clock is normally supplied complete with a timing-optimised narrow-band antenna together with 15m of lead-in cable. This combination provides an overall gain near the optimum.

If required, the lead-in cable can be extended to 60m using the same type of cable without the need for any additional amplification. For longer lead-in lengths, either amplification and/or larger diameter, lower loss cable can be supplied to order.

A Lightning Protection device may be inserted into the antenna lead. A suitable device complete with additional cable connectors, a connector crimping tool and mounting hardware is available as an option (see [section 5.2](#) p11). Introduction of the lightning protector does not degrade the performance of the antenna system.

#### P4: RS232 I/O (Serial port plus output)

An RS232 port (+/-9V signal levels) is implemented via 9-way “D” male connector with signal lines: **pin 2** (serial data OUT from TCG 1000), **pin 3** (serial data IN to TCG 1000) and **pin 5** (signal ground) together with a programmable signal output on **pin 1**. The programmable output shares the **pin 5** (signal ground).

The port is a DCE configuration, so that a “straight-wired” Socket-to-Socket 9-way data cable can be used to connect directly to a standard PC serial port. (A suitable 2m cable is included with each TCG 1000.) The CTS and DSR functions are permanently asserted, so the serial port does not support hardware handshake control. On Rev C and later units, **pin 9** can function as an RS232 level general-purpose input pin (in parallel with, but isolated from, the input on **P6** – (see below).



**Fig 3. P4-RS232 port & earth stud**

The RS232 signal lines are not HV-isolated from each other, but the port as a whole is isolated to a level of 2.5kV.

#### Earth stud

An M4 bolt (to chassis) is provided for earthing of cable shields.

#### P7

A set of isolated changeover relay output via 3-pin plug-able connector – capable of switching up to 2A of AC/DC external load (230V AC). Wiring size is to 1.5mm<sup>2</sup>, or to 1.0mm<sup>2</sup> on Rev-C and later units. Isolation is 2.5kV minimum.



## 4.2 Input/Output - Functions & Applications

### Programmable output (P4-pin1)

The RS232 output P4-pin1 is programmable to provide one of the following options:

- i) DCF-77 pulse simulation
- ii) Unmodulated (i.e. DC level-shift) IRIG-B (B00x)
- iii) Modified Manchester Modulated IRIG-B (B22x)
- iv) Programmed pulse sequence

In the case of option iv) above, separate settings are provided so that a differently-programmed pulse sequence can be specified for each of the three outputs.

The output can also be inverted in its operation.

Full details on configuring the programmable output is contained in [section 6.3](#) p14.

A common application for the programmable output on P4-pin1 (RS232 level) is to provide an independent drive to an RS232-Fibre converter unit for use in transporting the code signals to a distant location. In such cases, **pin 1** should be “broken out” of the normal 9-way cable optionally used to connect to an external PC, and used in conjunction with **pin 5** (signal return).

Tekron manufactures a range of interface devices (MOFRs) that includes such converters.

### Serial Port (P4 –pins 2,3 and 5)

The serial port can be configured to output any one of a number of different serial time messages on a broadcast basis.

The serial port runs at a fixed baud-rate of 9600 baud. Message formats operate at 8-bit no parity, no flow control, and are transmitted once per second unless otherwise noted below.

Alternative message strings / data formats and protocols currently available include for output on this port include:

Motorola Binary protocol	Message transmitted once per second
NGTS protocol	Message transmitted once per minute
IRIG J-17	7-bit ASCII – odd parity
Tekron-A	
Tekron-B	
Tekron-C	
Tekron-D	
Tekron-E	

(see [Section 6.5](#) p15 for details of each of the message string formats).

- Additional string options can be provided if necessary to meet specific customer requirements. Please consult TEKRON for details. TEKRON design engineers can assist both in clarifying specific needs and providing solutions with a very fast turn-around time, typically within just a few days.

**P7: Relay Output (“Sync” relay)**

A set of changeover contacts is provided via a three-pin plug-able connector. This relay is active (“C” and “NO” connected) whenever the TCG 1000P has established stable time sync from the GPS satellites. The active relay output indicates that all of the other output signals are operating within specification. The connector accommodates 1mm<sup>2</sup> cabling. The sync relay can be configured to remain active (indicating “in sync”) for a period following the loss of satellite signals. The default period is one minute, but this can be altered up to a maximum period of 42:30 (2550 seconds).

**4.3 Indicators & Display Unit**

TCG 1000 features two LED indicators on the front panel.

**SYN:** This LED operates in parallel with the Sync Relay, and is active at all times when the unit is operating with time code outputs within specification. (i.e. time accurately tracking the GPS time signals)

**GPS:** Flashing cadences are used on this indicator to indicate the status of the GPS receiver (see [Section 3.1](#) p6 for details)

**4.4 Power Requirements**

Standard Power Supply is: DC: 12-36 Volts (AC: 15-24V<sub>rms</sub> may be used also). Maximum power consumption is 6W. Connection is via the 2-pin plug-able connector **P1** on rear panel. The power input is *not* polarity-sensitive (despite the markings). The casing is isolated from the power supply inputs so that either (or neither) power supply polarity can be earthed to station earth.

20-72Volt DC, and 90-350 Volt DC power supply options are available as factory-fitted options. (See [Section 5.1](#) p11 for full details on power supply options)

**4.5 Isolation & Protection**

All inputs and outputs feature 2.5kV isolation from each other.

The power supply input also features Varistor and fuse protection. (20mm barrel fuse, slow-blow, 500mA, accessed via rear panel).

Transformer isolation via DC-DC converter is used for the main power supply. The serial communications interface is powered via isolating DC-DC converter. High-speed, fixed delay opto-isolators are used in the time-sensitive signalling paths. The isolation does not degrade the time accuracy of the output signals, as the fixed delays of the isolating components (together with the delay associated with the antenna lead-in) are all internally compensated.

**4.6 Dimensions**

Width: 160mm. Depth: 155mm. Height: 1U. Weight: 0.8Kg.

Each TCG 1000 unit is normally supplied complete with antenna, antenna mount, antenna cable and 19” rack-mount hardware. Shipping weight of the complete TCG 1000 kit is 4.5Kg.

**4.7 Identification**

Each TCG 1000 unit is shipped with an identification label on the base. The label provides details of the particular options fitted to the unit, the power supply requirement, and the serial number.

## 5. FACTORY HARDWARE OPTIONS

### 5.1 Power Supply Options – Opt. 2M, Opt. 2H

There are three different power supply configurations for the TCG 1000.

- a) Order **Standard Nominal 24Vdc**  
This supply operates with DC input in the range 12 –36Vdc,  
or with AC input in the range 16-24Vac
- b) Order **Opt.2M Nominal 48Vdc**  
This supply operates with DC input in the range 20-72Vdc,  
or with AC input in the range 24-48Vac
- c) Order **Opt 2H Nominal 110/240Vdc**  
This supply operates with DC input in the range 90-350Vdc,  
or with AC input in the range 80-240Vac

### 5.2 Lightning Protection Kit – Opt. 4

A lightning Protection kit is available for fitting into the antenna lead-in cable. The kit contains a protection device, two coaxial cable connectors, a connector crimp tool, and mounting hardware for the protection device. Full instructions relating to the installation and maintenance of the lightning protector are included with the kit, together with some guidelines as to best positioning of the antenna and protector unit to minimize the possibility of lightning-induced damage to the TCG 1000 base unit.

- While the LP kit provides a high degree of protection, there is no absolute guarantee of protection against a direct lightning strike to the antenna. Careful antenna positioning is strongly advised!

## 6. TCG 1000 CONFIGURATION SOFTWARE

A proprietary software configuration program ships with all units. It provides the user access to all of the TCG 1000 programmable system operating parameters as well as the programmable output options. These parameters are stored in EEPROM within the unit. If preferred, parameter set-up can be carried out ex factory to customer specification. In addition to the descriptions below, the various configurable parameters are also described within the program's on-line help. A "click" on the ? icon in the top RH corner of the window brings up the help cursor. Moving the cursor to any parameter and "click"ing or pressing **F1** while over a parameter brings up the help for that parameter.

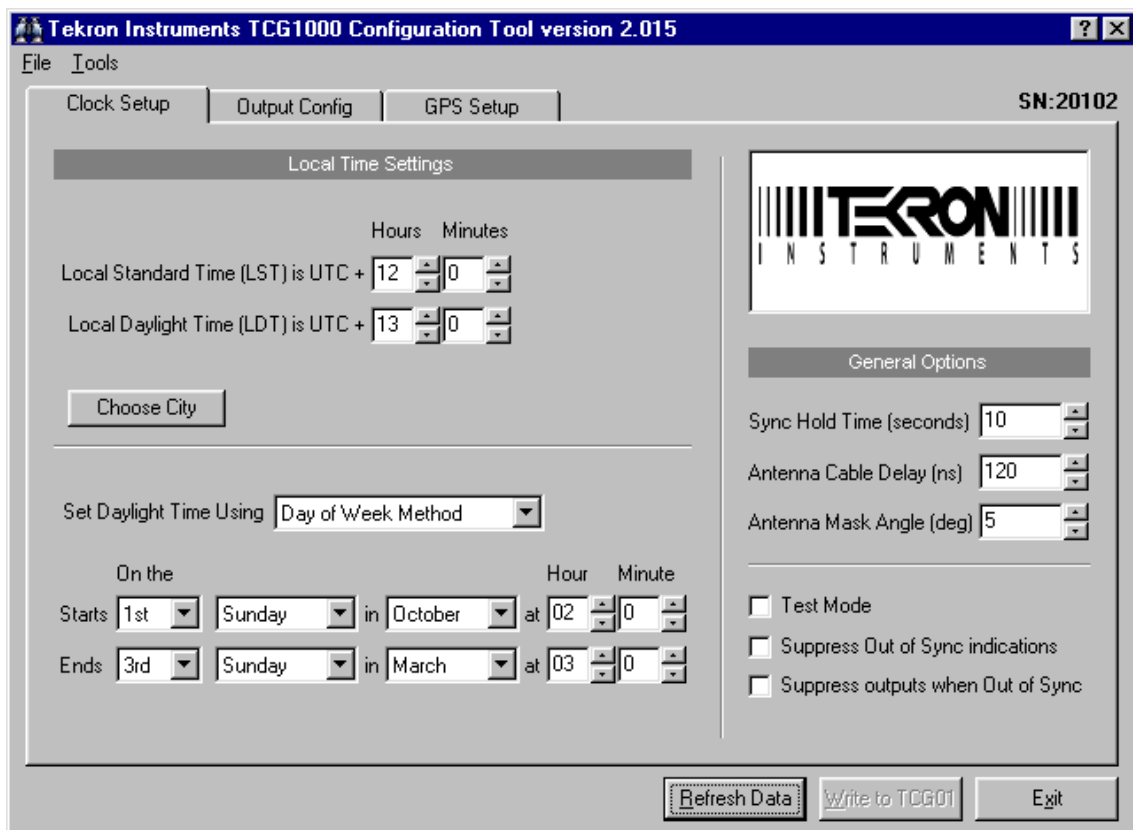

Fig 4. Configuration program (TCG 1000.EXE Ver 2.015) Clock Setup screen

### 6.1 General Options

#### Sync Hold Time

The "Sync Hold" parameter is used to control the time duration with no satellites visible that will be tolerated before TCG 1000 will release the "sync" relay, and show loss of sync. The TCG 1000 antenna should be sited with a good view of the sky so that the unit normally tracks 4 or more satellites. In areas with poor GPS coverage there may be occasions where tracking is momentarily lost. Under these circumstances, TCG 1000 will begin to drift relative to absolute UTC time. The accuracy of TCG 1000 outputs even when there is a complete satellite "blackout" is maintained to within a few micro-seconds over time periods of around a minute, and to within 200uS for up to 40 minutes. The presence of just one satellite signal is sufficient to reset output accuracy to within 1uS, and therefore reset the Sync Hold timeout.

- In typical SCADA operations, time syncing to within 0.5mS is considered adequate, so setting the Sync Hold number to the maximum tolerance (representing 42.5 minutes) would be quite in order, as even in this worst case, TCG 1000 performance is more than adequate. This may be a worthwhile strategy to minimise unnecessary “loss of sync” (relay drop-out) alarms when the sky view is very obstructed, or in extremely hostile electromagnetic environments.

The factory default setting for the Sync Hold Parameter is 60 (1 minute delay)

### Test Mode

Test Mode forces TCG 1000 to provide all outputs as if it is in sync at all times, even if there is no antenna attached. The sync relay will be on at all times, regardless of the true sync state. This is a test-only mode and should not be used during normal operation.

### Suppress Out of Sync Indications

This makes TCG 1000 operate as if it is in sync at all times, even if there is no antenna attached. The sync relay will still indicate the true satellite sync status.

### Suppress Outputs When Out of Sync

This option suppresses the TCG 1000 output signals when the clock goes out of sync. The sync relay operation is unaffected by this option and will still indicate the true sync state of TCG1000.

### Antenna Cable Delay Compensation

This parameter is measured in nanoseconds. All antenna systems introduce delay due to the characteristics of the antenna cable. TCG 1000 compensates for this delay to optimise the precision of the output signals. The standard 15m cable supplied with TCG 1000 introduces 60nS of delay, the 30m cable 120ns of delay and 60m cable 240ns of delay, ensure the Antenna cable delay is set to the correct value.

### Mask Angle

This is the elevation above the horizon below which specific satellite signals will not be used in time and position calculations. The factory default value is 5 degrees. Range: 0-90.degrees.

Where the antenna view of the sky is severely restricted, in rare circumstances, altering this value may give some fine improvement in stability of the time signal. Increasing the angle reduces the likelihood of errors being introduced by multi-path signals from low elevation satellites (typically caused by reflections off land-based obstacles), but narrows the overall field of view.

## 6.2 Local Time Settings

### Local Time Offset (from UTC) – also known as “GMT Offset”

Local Standard Time Offset:	( +/--hh:mm)	{NZ: +12:00}
Daylight Saving Time Offset	( +/- hh:mm)	{NZ: +13:00}

The time offsets define the number of hours (and, in rare cases, minutes) that the local time differs from UTC time. A positive offset means that the local time is *ahead* of UTC.

If automatic Daylight Saving Time operation is not required, both of the offsets should be set to the same value. For UTC operation, both values should be set to zero.

### Automatic Daylight Saving Parameters

In TCG 1000 units with firmware earlier than Rev .6, these parameters must be specified as follows:

Daylight Saving “on” date and time (n<sup>th</sup> Sunday of m<sup>th</sup> month) {NZ: 1, 10}

Daylight Saving “off” date and time (n<sup>th</sup> Sunday of m<sup>th</sup> month) {NZ: 3, 03}

In later revisions of the firmware, the above format can be varied to specify any day of the week and not just Sunday. It is also possible to specify absolute dates in later firmware.

In the absence of specific instructions at the time of order, the factory default settings for GMT Offset and Daylight Savings parameters are set to match the published time conventions of the shipping destination.

The “Choose City” button provides a convenient way of selecting daylight savings parameters.

### 6.3 Programmable Outputs

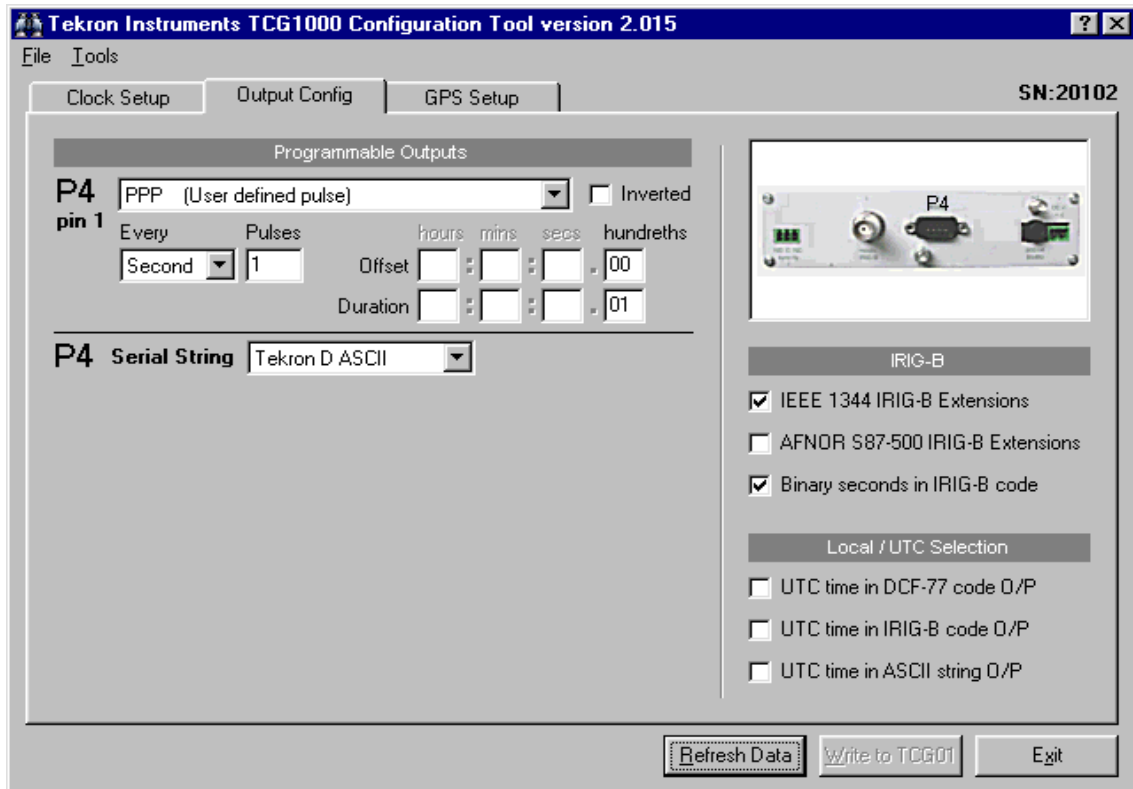

Fig 5. Output Configuration in version 2.015 of configuration software

#### Signal Options (P4-pin 1)

Output P4-pin 1 can be programmed to give one of four different output waveforms. Selection between the four options is done via a drop-down menu.

The options available for the output are:

- i) DCF-77 output pulse simulation
- ii) IRIG-B NRZI (B000/B001 or B002/B003)

- iii) IRIG-B Modified Manchester Encoded (B220/B223 or B221/B222)
- iv) User Defined Pulse Sequence

In the case of the User-Defined Pulse option being selected for the output, further parameters are entered to define the pulse sequence. The parameters are as follows:

- a) A drop-down menu “Every” allows the user to select between having pulses output per second, per minute, per hour, or per day.
- b) The “Pulses” field defines how many pulses will be produced in the selected time interval. Selection is automatically constrained to even divisors of the time interval. For example, if the time interval selected is per minute or per hour, then the “Pulses” parameter is limited in values to 1, 2, 3, 4, 5, 6, 10, 12, 15, 20 or 30. For more information position the mouse over the “Pulses” field or “Every” menu and press the F1 key.
- c) The “Offset” data entry boxes specify how much time elapses into the defined time interval before pulsing starts. Data validation rules ensure that only sensible entries can be made.
- d) The “Duration” data entry boxes specify the length of individual pulses.

Fig 4 shows the settings for a user-defined pulse on the P4-pin1 output.

Selection between the four basic options for each programmable output is normally achieved as described above, using the configuration program, TCG 1000.EXE.

By prior arrangement, TCG 1000 can be shipped ex factory with output configuration and operating parameters as required, thus eliminating the need for *any* field programming of the unit at all.

## 6.4 IRIG-B Options

**Binary Seconds in IRIG-B.** The “Binary Seconds” field is an option specified by IRIG standard 200-98. If this option is checked, the IRIG-B code will include the “Binary Seconds of Day” data.

**IRIG-B Extensions.** IRIG Standard 200-98 specifies a 27-bit control field in the IRIG-B time codes, but does not define the content. There are now two standards defined for the use of these control bits. IEEE 1344 and AFNOR NF S87-500.

### IEEE1344 Extensions (US origin)

The IEEE 1344 IRIG-B extensions define data for

- Year;
- Impending leap second info;
- Local time offset info;
- Impending daylight savings change info;
- Time-quality figure.

### AFNOR S87-500 Extensions (European Origin)

The AFNOR NF S87-500 extensions define data for:

- day of year;
- day of week;
- year;
- month;
- day of month.

If either option is checked, the IRIG-B code will include the extension data in the control field.

## 6.5 Serial Port Output Options

The serial port output **P4** operates at the fixed data rate of 9600bd, no matter what output string option is specified. There is no flow control of any kind provided. Unless specified otherwise, all serial string options are sent in 8-bit, no parity format. TCG 1000 does not offer any polled message options, but rather, has a selection of broadcast messages that are sent at regular intervals. The broadcast repetition rate of each particular serial option is inherent in the option specification. (Mostly one message per second).

In the default configuration, TCG 1000 outputs a binary message sequence on the Serial port **P4** each second. This format, proprietary to Motorola, is used to communicate directly with the GPS receiver embedded in TCG 1000, and is used during factory testing.

**NGTS Time Code O/P on P4.** Causes TCG 1000 to output an ASCII time string once per minute. The string is sent during the last quarter of the last second *before* the minute rollover to which the data in the string refers. It is normally used in conjunction with a 10mS pulse programmed for output on **P4-pin1** and generated once per minute, finishing precisely on the minute. (See [section 6.3](#) p14 for details on programming pulses.)

The NGTS time code string content is:

character no.	Meaning	value / value range
1	"T" ASCII T	\$54
2	tens year	\$30-39
3	unit year	\$30-39
4	tens month	\$30-31
5	unit month	\$30-39
6	tens day	\$30-33
7	unit day	\$30-39
8	day of the week	\$31-37 (Monday=1)
9	tens hours	\$30-32
10	unit hours	\$30-39
11	tens minutes	\$30-35
12	unit minutes	\$30-39
13	status (0=local, 1=UTC)	\$30-31
14	CR (carriage return)	\$0D
15	LF (line feed)	\$0A

**Example:** T020422112340<CR><LF> reads as: Monday 22 April 2002 – 12:34 local time

**IRIG J-17 Time Code O/P on P4.** This serial time code option is fully specified in IRIG Standard 212-00. The string is transmitted once every second, with the leading edge of the “start” bit of the first character (<SOH>) exactly on the second mark to which the message data refers. The message data is thus transmitted immediately *after* the event. The accuracy of the positioning of the message start is limited by the latency of the serial port transmission hardware to within 150microSec of the Second mark. For many applications, this accuracy is sufficient for this message to be used for synching purposes as well as providing the time data. The data format is specified to be 9600bd, **7-bit ASCII, odd parity.**



The IRIG J-17 string content is:

character no.	meaning	value / value range
1	SOH (start of header)	\$01
2	day of year: hundreds	\$30-\$33
3	day of year: tens	\$30-\$39
4	day of year: units	\$30-\$39
5	“:” ASCII colon	\$3A
6	hour: tens	\$30-\$32
7	hour: units	\$30-\$39
8	“:” ASCII colon	\$3A
9	minute: tens	\$30-\$35
10	minute: units	\$30-\$39
11	“:” ASCII colon	\$3A
12	second: tens	\$30-\$36
13	second: units	\$30-\$39
14	CR (carriage return)	\$0D
15	LF (line feed)	\$0A

**Example:** <SOH>112:12:34:36<CR><LF> reads as: day 112, time 12:34:36

**Tekron-A Time Code O/P on P4.** This code is very similar in data content to the IRIG J-17 code (see above), but adds a two-character data field containing the year data, and uses 8-bit ASCII, no parity data format. The string is transmitted once every second, with the leading edge of the “start” bit of the first character (<SOH>) exactly on the second mark. The accuracy of the positioning of the message start is limited by the latency of the serial port transmission hardware to within 150microSec of the Second mark. For many applications, this accuracy is sufficient for this message to be used for synching purposes as well as providing the time data. The Tekron-A string content is:

character no.	Meaning	value / value range
1	SOH (start of header)	\$01
2	day of year: hundreds	\$30-\$33
3	day of year: tens	\$30-\$39
4	day of year: units	\$30-\$39
5	“:” ASCII colon	\$3A
6	hour: tens	\$30-\$32
7	hour: units	\$30-\$39
8	“:” ASCII colon	\$3A
9	minute: tens	\$30-\$35
10	minutes: units	\$30-\$39
11	“:” ASCII colon	\$3A
12	second: tens	\$30-\$36
13	second: units	\$30-\$39
14	“:” ASCII colon	\$3A
15	year: tens	\$30-\$39
16	year: units	\$30-\$39
17	CR (carriage return)	\$0D
18	LF (line feed)	\$0A

**Example:** <SOH>112:12:34:36:02 <CR><LF> reads: day 112 of year 2002, time: 12:34:36

**Tekron-B Time Code O/P on P4.** This code substitutes a “Quality” indicator byte for the year field, but otherwise is identical in form, function and timing to Tekron-A described above. Tekron-B string content is:

character no.	Meaning	value / value range	“Quality” values
1	SOH (start of header)	\$01	
2	day of year: hundreds	\$30-\$33	\$20 (space) = in sync
3	day of year: tens	\$30-\$39	
4	day of year: units	\$30-\$39	\$2E ( . ) = < 1uS
5	“:” ASCII colon	\$3A	
6	hour: tens	\$30-\$32	\$2A ( * ) = < 10uS
7	hour: units	\$30-\$39	
8	“:” ASCII colon	\$3A	\$23 ( # ) = < 100uS
9	minute: tens	\$30-\$35	
10	minute: units	\$30-\$39	
11	“:” ASCII colon	\$3A	\$3F ( ? ) = > 100uS
12	second: tens	\$30-\$36	
13	second: units	\$30-\$39	
14	“Quality” character	see column	
15	CR (carriage return)	\$0D	
16	LF (line feed)	\$0A	

**Example:** <SOH>112:12:34:36?<CR><LF>  
The example reads: day 112, time: 12:34:36, >100uS sync error

**Tekron-C Time Code O/P on P4.** This code is effectively a combination of Tekron-A and Tekron B, and provides both year information and a sync indicator field. It uses 8-bit ASCII, no parity data format. The string is transmitted once every second, with the leading edge of the “start” bit of the first character (<CR>) exactly on the second mark. The accuracy of the positioning of the message start is limited by the latency of the serial port transmission hardware to within 150microSec of the Second mark. For many applications, this accuracy is sufficient for this message to be used for synching purposes as well as providing the time data. Tekron-C string content is:

character no.:	Meaning	value / value range
1	CR (carriage return)	\$0D
2	LF (line feed)	\$0A
3	Quality	space = in-sync, “?” = out-of-sync
4	“ ” ASCII space	\$20
5	year: tens	\$30-\$39
6	year: units	\$30-\$39
7	“ ” ASCII space	\$20
8	day-of-year: hundreds	\$30-\$33
9	day-of-year: tens	\$30-\$39
10	day-of-year: units	\$30-\$39
11	“ ” ASCII space	\$20
12	hour: tens	\$30-\$32

13	hour: units	\$30-\$39
14	“.” ASCII colon	\$3A
15	minute: tens	\$30-\$35
16	minute: units	\$30-\$39
17	“.” ASCII colon	\$3A
18	second: tens	\$30-\$36
19	second: units	\$30-\$39
20	“.” ASCII period	\$2E
21	“0” ASCII zero	\$30
22	“0” ASCII zero	\$30
23	“0” ASCII zero	\$30
24	“ ” ASCII space	\$20
25	“ ” ASCII space	\$20
26	“ ” ASCII space	\$20

**Example:** <CR><LF>?\_02\_112\_12:34:36.000\_ \_ \_ (“ ” denotes a space)  
reads: day 112 of year (20)02, time: 12:34:36, out-of-sync

**Tekron-D Time Code O/P on P4.** This is available in C7 firmware or later. It is identical in content to Tekron B, the difference is that the leading edge of the start-bit of the (<CR>) is exactly on the second mark.

**Tekron-E Time Code O/P on P4.**  
This is available in C7 or later firmware. 8-bit ASCII, no parity data format. The string is transmitted once every second, with the leading edge of the “start” bit of the carriage return (<CR>) exactly on the second mark. The accuracy of the positioning of the message start is limited by the latency of the serial port transmission hardware to within 150microSec of the Second mark. The Tekron-E string content is:

<b>character no.</b>	<b>Meaning</b>	<b>value / value range</b>	<b>“Quality” values</b>
1	SOH (start of header)	\$01	
2	year: hundreds	\$30-\$39	
3	year: tens	\$30-\$39	
4	year: units	\$30-\$39	
5	“.” ASCII colon	\$3A	
6	day of year: hundreds	\$30-\$33	\$20 (space) = in sync
7	day of year: tens	\$30-\$39	
8	day of year: units	\$30-\$39	\$2E (.) = <1uS
9	“.” ASCII colon	\$3A	
10	hour: tens	\$30-\$32	\$2A (*) = <10uS
11	hour: units	\$30-\$39	
12	“.” ASCII colon	\$3A	\$23 (#) = < 100uS
13	minute: tens	\$30-\$35	
14	minute: units	\$30-\$39	
15	“.” ASCII colon	\$3A	\$3F (?) = < 100uS
16	second: tens	\$30-\$36	
17	second: units	\$30-\$39	
18	“Quality” character	See column	
19	CR (carriage return)	\$0D	
20	LF (line feed)	\$0A	

**Example:** <SOH>004:112:12:34:36?<CR><LF>

The example reads: year (2)004, day 112, time: 12:34:36, >100uS sync error

## 6.6 GPS Setup

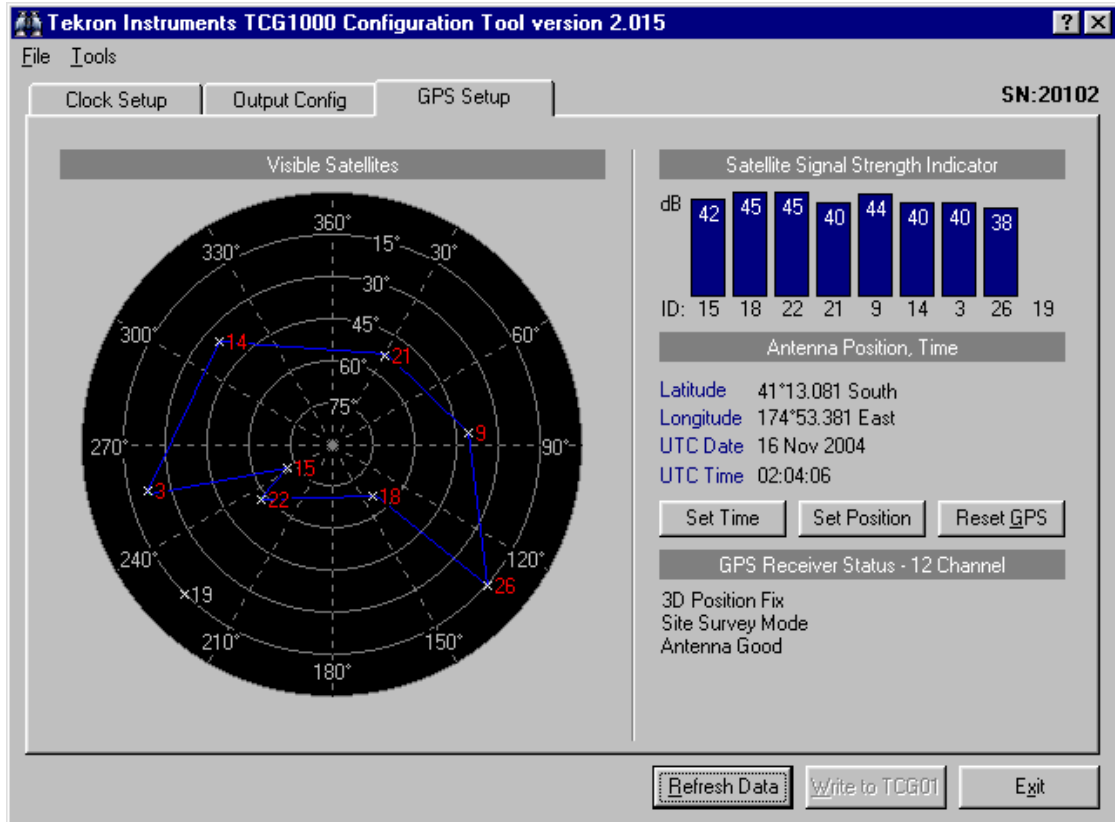

**Fig 5. GPS setup (TCG 1000 Version 2.015)**

The GPS Set-Up page provides information about the GPS system. As well it allows some commands to be sent to the GPS.

### Visible Satellites

Visible satellites are shown on a polar-display where the rings are 'elevation' markers and the sectors mark 'azimuth'. The centre of the display is where all the azimuth lines converge, and represents directly overhead, or looking straight up, and the elevation = 90° at this point. The edge of the display, elevation = 0°, represents the horizon. The 'azimuth' is a compass direction where 0° represents true north, 90° is east, 180° is south. Satellites are represented by x's. If a satellite is being tracked for time sync it will have a red number next to it.

Right clicking over the Visible Satellites area, brings up a menu where satellite trails (green lines), and a minimum elevation plot (the blue lines) can be turned on. Over time the blue line will show the horizon line, as well as areas where there is poor GPS constellation coverage.

### **Satellite Signal Strength Indicator**

The received signal strength of satellites being used for time calculations are shown here. The white numbers are a cross reference to the satellite number on the Visible Satellites display.

### **Antenna Position / Time**

Shows the current position and time. Time and position can be set if TCG 1000 is **not** tracking satellites (ie there are no blue bars in the "Satellite Signal Strength Indicator"). One way to achieve this is to remove the antenna and cycle unit power. Alternatively the "Reset GPS" button can be pressed, although the GPS will then lose all its satellite positioning information, past satellite history and time calculations. It will take time (normally up to half an hour) to retrieve this again. As well a reset of the GPS will reset TCG 1000.

- **A full reset of the GPS in TCG 1000 should ONLY be executed by experienced technical personnel under controlled circumstances, such as to facilitate laboratory testing of external equipment as described below**

The ability to force any time and date into the instrument means that TCG 1000 may be used as a convenient signal source for testing the ability of externally attached equipment to correctly process received time codes through particularly critical time transitions, (such as the 28/29 Feb rollover during leap years etc). It also allows the correct operation over daylight savings transitions to be conveniently checked, by setting the time to just a short period prior to the expected transition time, then waiting for the transition to tick by.

## APPENDICES

### Appendix A – Antenna Details

#### A.1 Antenna Cable Specification

The TCG 1000 unit's standard shipping configuration includes 15 metres of cable factory-fitted with an N-type male connector at one end, and an SMA male connector at the other. The N-type connector mates with the connector on the included antenna and provides a robust and weather-resistant connection. The much smaller SMA connector mates with the connector on the TCG 1000 rear panel and is only fractionally larger in diameter than the cable itself. This facilitates installation in conduit and through small apertures.

The supplied cable has the following characteristics:

Centre conductor:	1.42mm diameter Solid bare copper
Dielectric:	3.81mm diameter Low loss, closed polyethylene foam (Cellular PE)
Shield:	3.94mm diameter Aluminium Laminated Tape bonded to the Dielectric, with a Tinned Copper Overbraid – 4.52mm diameter
Jacket:	6.10mm Black Polyethylene
Bending Radius:	40mm (maintaining less than 1 ohm impedance change at bend).
Weight:	0.051 kg/metre
Temperature Range:	-40°C to +85°C
Impedance:	50 ohms
Velocity:	84%
Capacitance:	79.4pf/metre
DC Resistance:	
- Centre conductor	10.5 ohms per 1000 metre
- Shield	12.8 ohms per 1000 metre
Attenuation:	0.33dB per metre @ 1575.42MHz (L1)
Shielding:	> 90dB
Phase Stability:	+/- 10ppm/degree C

This is a high performance RF cable, and care should be taken during installation to ensure that the minimum bending radius limit noted above is scrupulously maintained.

Optional cable lengths of 30m or 60m are also available.

- While the cable shielding is excellent, the cable should not be routed in close proximity to power cables or other RF cables carrying transmitter signals. – in particular, parallel runs are to be avoided if possible. If such runs are absolutely unavoidable, a minimum separation of 30cm may be used as a guideline.

**The GPS receiver embedded in TCG 1000 has excellent OOB rejection characteristics, as does the antenna itself. However, sound engineering practice should not rely on these factors alone to guarantee performance. Careful installation will enhance the long-term reliability and on-going stability of the Time Code Generator.**

## A.2 Antenna Specification

The TCG 1000 unit's standard shipping configuration includes an active GPS antenna specifically designed for industrial/static timing environments, together with a mounting bracket.

<b>General Characteristics</b>	Antenna Description	Active microstrip patch antenna Molded UV-resistant plastic conical radome Aluminium die cast bottom housing Electrically shielded low noise amplifier assembly
<b>Performance Characteristics</b>	Operating Frequency Input Impedances	L1 (1575.42 MHz, +/- 2MHz) 50 Ohm
	VSWR Bandwidth	1.5 (typical) @ 1575.42 MHz 25 MHz (typical +/- 3dB points) filtering is 40dB not 4dB at +/- 50MHz
	Polarization Azimuth Coverage Elevation Coverage	Right hand circular 360° 0° to 90°
	Gain Characteristics of Antenna Element Filtering	+2.0 dBic minimum at zenith -10 dBic minimum at 0° elevation 4dB minimum @ +/- 50 MHz
<b>Electrical Characteristics</b>	LNA Gain Noise Figure Dynamics Power Requirements	25dB (typical) < 1.5dB (typical) Vibration: SAE J1455 5 +/- 0.25 Vdc
<b>Physical Characteristics</b>	Power Consumption Dimensions Weight Mount Connector	26 mA @ 5 Vdc (typical) 102.0 diameter x 82.0 height (mm) 312 grams Center mount M28 nut N-Connector (jack style)
<b>Environmental Characteristics</b>	Operating Temperature  Storage Temperature Humidity UV Radiation  Salt Spray Test Immersion Test Transient Voltage Test	-40°C to +85°C  -40°C to +85°C 85% noncondensing +30°C to +60°C JIS D0202 (Sunshine carbon Arc System)  Spray 5% NaCl solvent at +35°C 1 meter (with connector sealed) +/- 12kV

### A.3 Antenna Mounting

#### Antenna Mount to a 1 inch Nominal Pipe

Figure below details the installation of the GPS antenna assembly to a 1 inch nominal pipe with the mounting bracket.

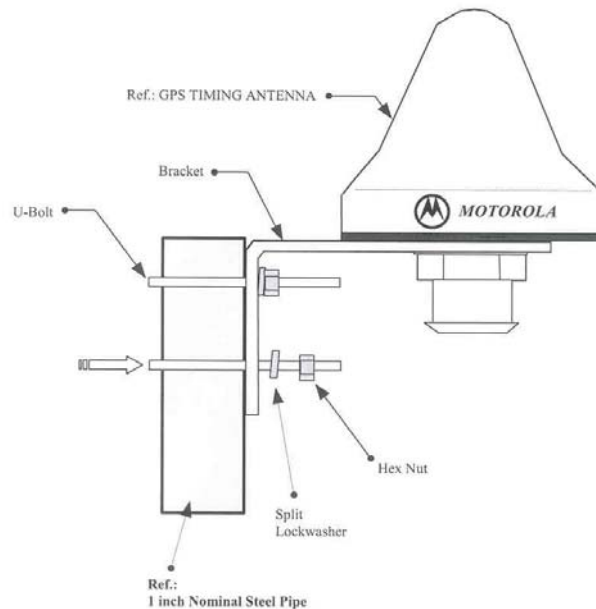

#### Extreme Weather and Environmental Conditions

To provide additional protection against extreme weather and environmental conditions, a plastic pipe tubing is recommended. This tubing should be secured to the mounting nut of the antenna assembly and should extend to the mating N-type cable plug. A product similar to Armaflex Pipe Insulation Tubing products is recommended. The figure below shows a pictorial overview of this recommendation.



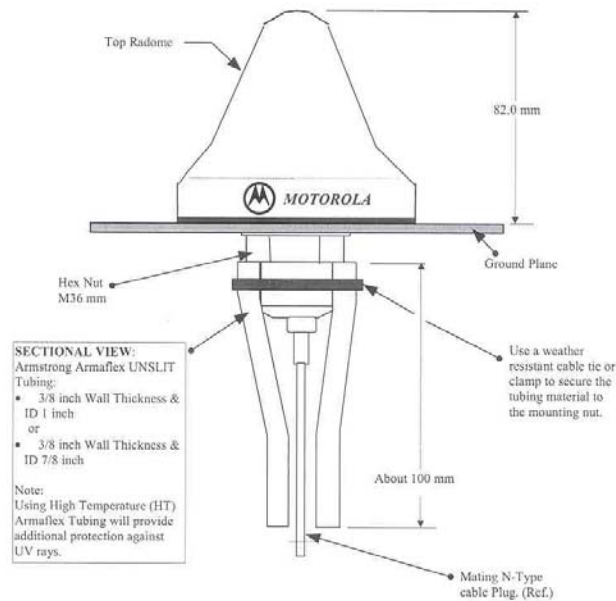

#### A.4 Antenna Lightning Protection Kit

LPK01 – Antenna Lightning Protection Kit - for use with TCG 1000 GPS- controlled Clock/Time Code Generator.

##### General

The GPS antenna supplied with TCG 1000 meets standard IEC100-4-5 for lightning protection. However, this will not provide immunity from damage caused by either a direct lightning strike, or from voltages induced in the antenna lead-in cable due to side flashes or induction.

The first line of protection against the effects of lightning-induced surge events involves positioning the antenna in a “lightning-protected zone” as far as is possible. In practice, this means ensuring that there is at least one other earth-bonded structure located in the same rooftop area (e.g. another antenna, or a lightning rod) that reaches significantly higher than the top of the GPS antenna. The GPS Antenna should then be mounted so that it lies within a 45-degree angle from the top of the other earth-bonded structure. The GPS antenna mount itself should also be securely bonded directly to the building protection earth – and *not* connected via any of the other earthed structures.

**All TCG 1000 antenna installations should follow the guidelines above – regardless of whether a separate lightning protection device is to be fitted to the antenna lead-in cable.**

In areas with a low incidence of electrical storms, careful attention to antenna positioning and earth connections may be all the protection deemed necessary.

The antenna lightning protection kit LPK01 affords additional security through the use of a gaseous discharge arrester cartridge mounted in an earthed casing. This assembly, known as an EMP protector, is installed in the antenna lead-in coax cable. In the event of a lightning-derived high voltage surge occurring on the coaxial cable, the discharge tube fires, short-circuiting the cable directly to the protection ground.

- **N.B. Although a correctly installed EMP Protector will provide enhanced security against lightning-derived damage to the TCG 1000 clock, there remains *no* absolute guarantee of full protection against all lightning-triggered surge events.**

The performance of the TCG 1000 antenna system under normal (non-surge) conditions is virtually unaffected by the introduction of a correctly installed EMP Protector.

**LPK01 Kit Contents**

- 1x Huber+Suhner EMP Protector type 3403.17.0023 (DC path maintained)
- 2x M4 Mounting bolts with nuts & serrated washers
- 2x N-type Male Crimp Style Coaxial cable connector set to match antenna cable
- 1x Crimp Tool to match the above connectors (RG59)
- 1x Roll Self-amalgamating Insulation tape

For the lightning protector to be effective, it must be firmly mounted to a conductive metal surface that is itself bonded to the building protective earth. **Please ensure that a good electrical connection is made between the surge protector and the earthing system.** The protector supplied features two mounting holes to accommodate M4 screws. The holes are on 24mm centres, one above the other (vertically orientated). The protector should be bolted to the plate so that the antenna connections are in the horizontal plane with the body of the protector below the antenna connection ports. When mounted correctly, the protector label should be readable directly, with the two M4 mounting screws and the additional earth connection stud on the left-hand side.

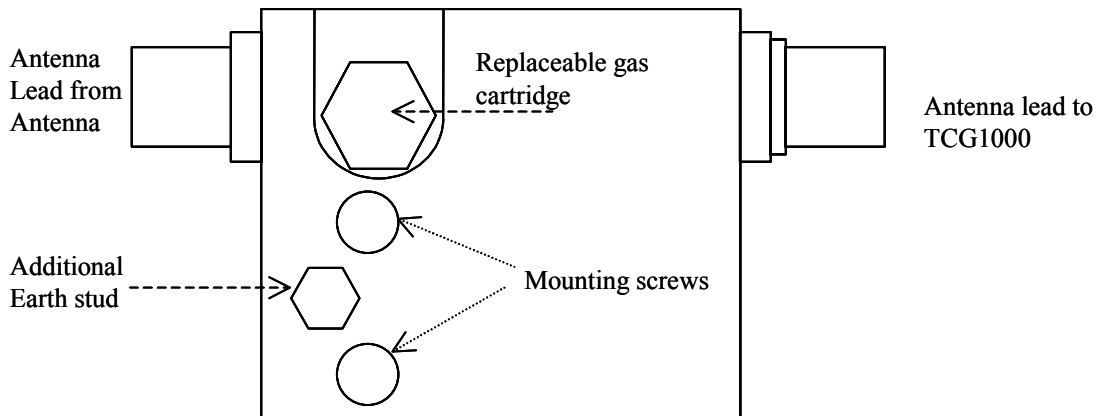

N.B. Drawing is approximate only – not to scale.

All earthing connections should be as short as possible, should have no sharp bends or loops and should not be coiled to take up extra cable.

The preferred mounting position is on the *inside* of the building’s exterior wall, adjacent to the antenna lead entry point. In the event of a lightning strike, it is likely that the gas-discharge cartridge on the protector will need replacing. It is therefore necessary to ensure that the protector is mounted so that there is room to place a 14mm open-ended spanner on to the Gas Cartridge cover. Care should also be taken to ensure that the antenna lead is not bent through too tight a radius at either the entry or exit points to the protector.

- The absolute minimum bend radius for the antenna cable supplied is 40mm, but it is preferable to use a larger bending radius if possible. One way of achieving this is by positioning the protector so that the incoming antenna lead comes through the wall about 150mm away from the protector's connector. This provides some space to ease the incoming cable into a gentle arc back on to the connector.

The antenna cable must be cleanly cut at the appropriate point and the resulting two ends terminated with the N-type connectors provided. The connectors are then attached to the protector assembly and tightened firmly by hand. Seal each of the connections by stretch-wrapping them with the self-amalgamating tape supplied in the kit. The seal provides protection against any moisture ingress, and prevents the connections from loosening over time.

Care must be taken to mount the N-type connectors to the coax cable correctly according to the drawing attached (T00100B3300). As the GPS antenna operates at a frequency in excess of 1.5GHz, it is *essential* that the cable be prepared *exactly* as per the drawing (**Use Option 2 measurements shown** – all measurements in millimetres). A purpose-built Crimp tool is included in the kit to aid the process – use the RG59(0.255) die for the external hex housing.

Montagecode  
**B33XX**  
assembly code

### Montageanweisung Assembly Instruction

Montagecode  
**B33XX**  
assembly code

Abisoliermaße *stripping instruction*

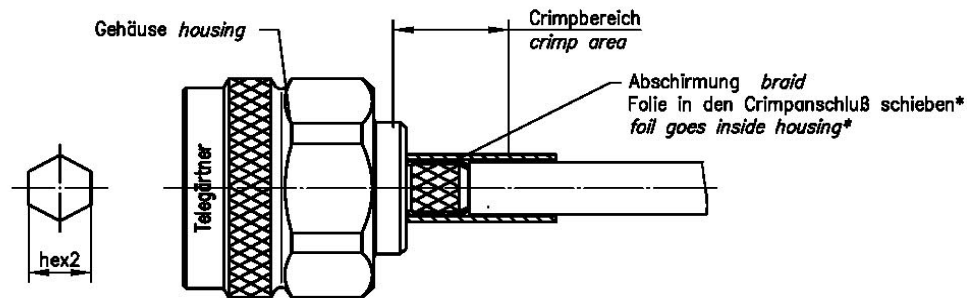
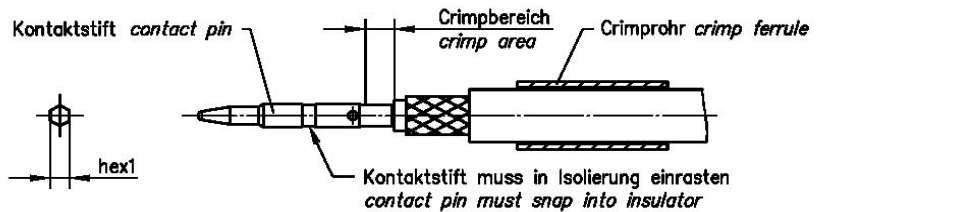
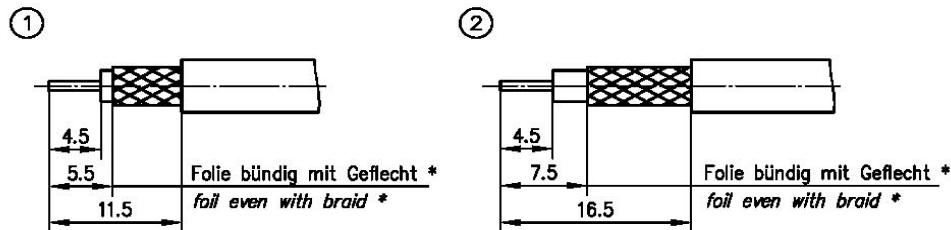

\* nur für Kabel mit Folie / only for cables with foil

XX	Crimpeinsatz crimp insert	6kt.1 x Länge hex1 x length	6kt.2 x Länge hex2 x length	Abisoliermaße stripping instruction	
05	N01001A0005	1.69x2.5	5.41x8	①	
06	N01001A0007	1.69x2.5	6.48x8	②	

Index index	Änderung modification	Datum date	Name name

	Datum date	Name name
Gez. drawn	29.08.00	HM
Gepr. app'd	11.10.00	GJ

**Serie N crimp**  
**Series N crimp**

Unter-  
Art  
R T00100B3300



Original  
original A4 Blatt  
sheet 1/1

Maßstab  
scale 2:1

Ersatz für/replacement for

Alle Rechte vorbehalten/All rights reserved © by Telegärtner K. GbRtnr GmbH D-71144 Steinbrunn Lärchenstr.35 Tel.: +49(0)7157/125-100 Fax: -120 URL: www.telegaertner.com

#### Disclaimer

**TEKRON INSTRUMENTS** disclaims any liability or responsibility for the results of improper or unsafe installation practice including, but not limited to, any excessive performance degradation of the TCG 1000 antenna system resulting from incorrect field installation of coaxial cable connectors.

---

## Warranty Statement

Tekron International Ltd (Tekron) warrants for a period of TWO years from the date of shipment that each Tekron Time Code Generator supplied shall be free of defects in material and workmanship. During this period, if the customer experiences difficulty with a product and is unable to resolve the problem by phone with Tekron Technical Support, a Return Material Authorisation (RMA) will be issued. Following receipt of an RMA number, the customer is responsible for returning the product to Tekron, freight prepaid. Tekron, upon verification of warranty will, at its option, repair or replace the product in question and return it to the customer, freight prepaid. No services are handled at the customer's site under this warranty.

Tekron shall have no obligation to make repairs, or to cause replacement required through normal wear and tear or necessitated in whole or in part by catastrophe, fault or negligence of the user, improper or unauthorised use of the Product, or use of the product in such a manner for which it was not designed, or by causes external to the Product, such as, but not limited to, power or failure of building services.

There are no understandings, agreements, representations or warranties, express or implied, including warranties of merchantability or fitness for a particular purpose, other than those specifically set out above or by any existing contract between the parties. Any such contract states the entire obligation of Tekron. The contents of this document shall not become part of or modify any prior or existing agreement, commitment or relationship.

The information, recommendation, description and safety notations in this or other documents supplied by Tekron are based on general industry experience and judgement with respect to such hardware and software. THIS INFORMATION SHOULD NOT BE CONSIDERED TO BE ALL INCLUSIVE OR COVERING ALL CONTINGENCIES. NO OTHER WARRANTIES, EXPRESS OR IMPLIED, INCLUDING WARRANTIES OF FITNESS FOR A PARTICULAR PURPOSE OR MERCHANTABILITY, OR WARRANTIES ARISING FROM COURSE OF DEALING OR USAGE OF TRADE, ARE MADE REGARDING THE INFORMATION, RECOMMENDATIONS, DESCRIPTIONS AND SAFETY NOTATIONS CONTAINED HEREBY AND IN HARDWARE AND SOFTWARE SPECIFICATION DOCUMENTATION, OR INSTRUCTIONS SUPPLIED BY Tekron. In no event will Tekron be responsible to the user in contract, in tort (including negligence), strict liability or otherwise for any special, indirect, incidental or consequential damage or loss of equipment, plant or power system, cost of capital, loss of profits or revenues, cost of replacement power, additional expenses in the use of existing software, hardware, equipment or facilities, or claims against the user by its employees or customers resulting from the use of the information, recommendations, descriptions and safety notations supplied by Tekron. Tekron liability is limited (at its election) to (1) refund of buyer's purchase price for such affected products (without interest); (2) repair of such products, or (3) replacement of such products, provided however, that the buyer follows the procedures set forth herein.

Warranty claims must be received by Tekron within the applicable warranty period. A replaced product, or part thereof, shall become the property of Tekron and shall be returned to Tekron at the Purchaser's expense.

**A return material authorisation number issued by Tekron must accompany all return material.**

---

The information in this manual may change without notice. The manufacturer assumes no responsibility for any errors that may appear in this manual.

Copyright 2003, Tekron International Ltd. All rights reserved. No part of the contents of this document may be transmitted or reproduced in any form or by any means without the written permission of Tekron International Ltd. Published in New Zealand.

### WARNING

This product has been designed to comply with the limits for a Class A digital device pursuant to Part 15 of FCC rules. These limits are designed to provide reasonable protection against such interference when operating in a commercial environment.