



TCG 1000P



TIME CODE GENERATOR User Manual

1st Edition: Nov 2004

TABLE OF CONTENTS

1	INTRODUCTION	3
2	INSTALLATION	4
2.1	Packing list	4
2.2	Mounting	4
2.3	Output Signals	4
2.4	Connections	5
3	OPERATION	6
3.1	Front Panel LEDs	6
4	SPECIFICATIONS	8
4.1	Input / Output – electrical / physical	8
4.2	Input/Output - Functions & Applications	9
4.3	Indicators & Display Unit	9
4.4	Power Requirements	10
4.5	Isolation & Protection	10
4.6	Dimensions	10
4.7	Identification	10
5	FACTORY HARDWARE OPTIONS	11
5.1	Opt1A, Opt1B - TCG 01 High Voltage Output Option	11
5.2	Opt. 2M, Opt. 2H - Power Supply Options	11
5.3	Opt 4 - Lightning Protection Kit	12
5.4	P2 & P3 Output Connector Options	12
6	TIME PARAMETERS	13
6.1	Local Time Settings	13
6.2	General Options	13
6.3	Output Configuration	14
6.4	GPS Receiver	15
	APPENDIX A – ANTENNA DETAILS	16
A.1	Antenna Cable Specification	16
A.2	Antenna Specification	17
A.3	Antenna Mounting	18
A.4	Antenna Lightning Protection Kit	19

1 Introduction

TCG 1000P Time Code Generators produce precision time code signals and pulses for use in synchronising industrial control and SCADA equipment.

They are ideally suited to providing time synchronisation simultaneously to many different devices, such as Remote telemetry Units (RTUs), Protection Relays and other Intelligent Electronic Devices (IEDs) typically deployed in electrical sub-stations and industrial control installations.

The TCG 1000P is fitted with two factory programmable outputs (which individually may be configured to output either a pulse of precise duration and offset, or one of a number of standard time codes). The unit also has a change over contacts sync status relay to provide positive indication when the unit is ‘in sync’ / ‘out of sync’.

The two programmable outputs may be fibre optic, TTL, RS422, or high voltage MOSFET switch with output connectors 2-pin plug, BNC or ST fibre optic.

The front panel has 2 LED indicators on the front panel which provide “at a glance” status information.



Fig 1 : TCG 1000 Front Panel

The optimised Receiver / Antenna system employed in TCG 01 provides time information from the GPS satellite constellation. Dynamic T-RAIM processing is used to eliminate any aberrant satellite signals from the timing solution. The result is timing precision on all outputs with accuracy similar to that normally seen only in laboratory instruments.

However, unlike laboratory instruments, TCG 01 is ideally suited for service in hostile electromagnetic environments such as sub-stations and electrical switchyards. The internal electronics are isolated from the outside world.

Each output is isolated from the other outputs, so that attached wiring can feed out to operating areas in different earth potential zones without compromising the overall site earthing security. Transient suppression networks on each i/o point mean that the unit is protected from both longitudinal and transverse high voltage events.

The TCG 01 unit occupies less than half the width of a 1U rack space. It is supplied complete with all hardware and software required for installation, including rack-mount kit, connectors, 15m lead-in antenna cable, and GPS antenna.

2 Installation

2.1 Packing list

Each TCG 1000P kit is shipped with the following:

- TCG 1000P Time code generator
- User Manual – this document
- GPS Antenna (optimised for stationary applications), with mounting bracket
- 15m of antenna lead-in cable (fitted with matching connectors)
- 19” Rack mounting Plate & fasteners
- Plug-in connector set (3 x 2way, 1x 3way miniature)

2.2 Mounting

The clock is designed to be mounted in a 19” rack, but may be used on a bench. The unit is attached to the rack mount plate via the four screws shipped installed in the four corners of the front panel.

GPS Antenna: Detailed antenna mounting instructions are contained in [Appendix A](#) p16. The antenna should be located in a position with as clear a view of the sky as possible, over as wide an angle as possible.

The antenna should also be mounted in a “lightning-protected zone” as far as is possible. In practice, this means ensuring that there is at least one other earth-bonded structure located in the same rooftop area (e.g. another antenna, or a lightning rod) that reaches significantly higher than the top of the GPS antenna. The GPS Antenna should be mounted so that it lies within a 45-degree angle “skirt” from the top of the other earth-bonded structure. The GPS antenna mount itself should also be securely bonded directly to the building protection earth – and *not* connected via any of the other earthed structures.

A lightning protection kit is available for installation in the antenna lead-in cable for additional protection of the equipment. (See [section 5.3](#) p12 for details.)

All TCG1000 antenna installations should follow the guidelines above

2.3 Output Signals

Each TCG 1000 unit signal configuration is factory set to the customer’s requirements prior to shipping, see [section 4.2](#) p9 for the output signal options. An example of the outputs is listed below:

Plug 2: 1PPS (100ms)

Plug 3: Unmodulated IRIG-B output

Plug 7: Sync Relay output (Change-Over contacts)

2.4 Connections

All connections to the unit are via the rear panel.



Fig 2 : TCG 1000P Rear Panel with 2-pin

- P1** Power is applied to the unit via this plug. Maximum power consumption is 6 watts. Despite the markings on P1, the polarity of the power connection is *not* important and the unit is fully isolated internally from the power source. A mating connector is supplied with the unit, suitable for wiring sized up to 1.5mm².

Check the option label on the unit base for power supply voltage ratings!!

- Ant** The antenna lead-in cable connects to the “Ant” connector located above P1. Care should be taken to ensure that the connector is not cross-threaded when attaching the antenna lead-in cable. The connector should be tightened firmly ***by hand only***.
- P2/P3** Programmable outputs. There are 4 output signal options available on these two outputs. Signal levels may be 5V TTL or +/-5V 422 or high voltage switch (See [Section 5.1](#) p11 for further details), or fitted with ST Fibre Transmitters (See [Section 5.4](#) p12 for further details). Connector options are 2-pin plug (wiring to 1.5mm²), BNC or ST fibre optic.
- P7** Sync status relay contacts. When the clock is in sync, the “NO” and “C” terminals are connected. A mating plug is supplied (Wiring to 1mm².)

3 Operation

Connect the antenna lead and the antenna (with a good view of the sky). Then connect the power source to **P1**.

Check the option label on the base for voltage requirements before switching on!

The time required to achieve tracking and synchronisation (given a good “view” of the sky) will vary from just a few seconds to around 45 minutes in the worst case – such as reactivating a unit that was previously synchronised 1000’s of km away from the present position.

3.1 Front Panel LEDs

The **GPS** LED shows the status of the GPS receiver, while the **SYN** LED shows the status of the time synchronisation to UTC reference time derived from the GPS satellites.

By default, all outputs become active within a few seconds of initial power-up even when the unit is not synced to GPS satellite time! Output time data is not precise until the unit is synced to the GPS satellite

Warning Status Indications – (SYN LED not illuminated)

The sync relay is deactivated (“C” connected to NC”). The accuracy of the clock outputs is not guaranteed correct for syncing purposes! The **GPS** LED shows warning states as follows:-

Warning Status 1: — — —

GPS LED flashing rapidly (at about 4 flashes per second): Either the antenna is not connected, or it is short or open-circuited. When the antenna is operating correctly, this sequence will not be seen.

Warning Status 2: — — —

GPS LED flashing with a two flash pattern, repeating each second: The unit is searching the sky for satellites to begin the sync process.

OK Status Conditions – (SYN LED illuminated continuously)

The sync relay output is activated, giving both visual and electrical indications that the system is operating normally. All of the output time data is then accurate and usable for sync purposes. There are two normal operating states:

OK Status 1: —————

The **GPS** LED flashes with a single flash each second, with the “ON” period much longer than the “OFF” period. The clock shows this status after first obtaining satellite sync. The long “ON” cadence shows that satellite tracking is operating. (The 2nd status character on the LCD display shows the number of satellites being tracked) Accuracy on all outputs is typically within 1microSec of UTC in this state. As soon as 4 or more satellites are being tracked, the unit starts a site survey. The survey determines the precise position of the antenna (Latitude, longitude and Height) by taking the average result of 10,000 position solutions based on data from 4 or more tracked satellites. A new position solution is calculated each second, so under “clear sky view” circumstances (at least 4 satellites tracked almost immediately from switch-on) the site survey will take about 3 hours. On completion of the survey, TCG 01 “freezes” the position and proceeds to the most accurate operating state, OK state 2 below.

OK Status 2:

The **GPS** LED flashes a one-second “heart-beat” as above, but with a shorter “ON” period than “OFF”. The 3rd status char on the LCD display shows **P**. In this mode, the embedded GPS receiver operates in “Position-Hold” mode and devotes all resources to resolving the most accurate time solution. Using T-RAIM processing, this mode yields the best steady-state timing accuracy that the clock is capable of viz: leading edge of output signals to within 60nanoSec, and typically to within 40nanoSec, of UTC time. (Provided that the antenna feed delay is compensated correctly – this is automatic when the clock is installed using the 30M-antenna cable normally supplied with the kit.

4 Specifications

4.1 Input / Output – electrical / physical

P2, P3: Outputs (Fig 4)

[a] 2-Pin Plug Connectors

CMOS/TTL (5V) logic level driver output ports rated at 150mA sink and source implemented via 2-pin plug connectors. (max. wiring size of 1.5mm²). Each port is fully floating and features independent electrical isolation to 2.5kV. As a factory option, either or both of these outputs can be fitted internally with a Power MOSFET Switch, allowing switching of up to 300VA, (1A max). See [Section 5.1](#) p11 for suggested wiring configurations for use with Power MOSFET switching.

[b] BNC Connectors

CMOS/TTL (5V) logic level driver output ports rated at 150mA sink and source implemented via BNC connectors. Each port is fully floating and features independent electrical isolation to 2.5kV. As a factory option, either or both of these outputs can be fitted internally with a Power MOSFET Switch, allowing switching of up to 300VA, (1A max). See [Section 5.1](#) p11 for suggested wiring configurations for use with Power MOSFET switching.

[c] ST Fibre Optic Transmitters

ST fibre transmitters, compatible with ST-terminated 62.5µm fibre diameter, 125µm jacket diameter multi-mode fibre optic cabling. The maximum length of fibre recommended is 700 metres.

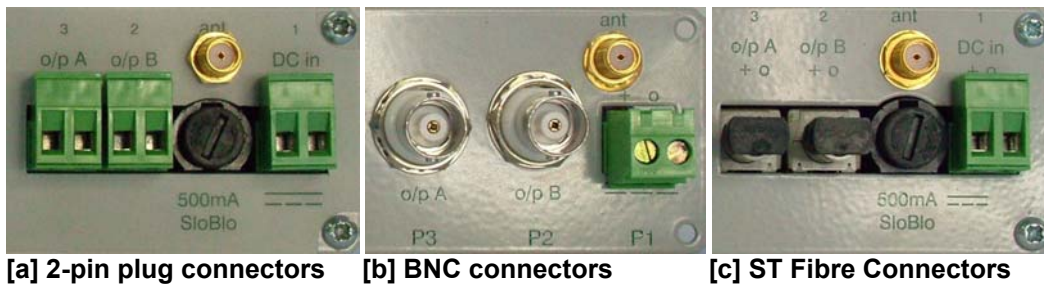

Fig 3. Power Input, Antenna Jack (SMA), Digital Outputs P3(A) & P2(B)

Antenna input “ant”: (SMA jack)

The antenna input provides an interface for an external active antenna via low-loss coaxial cable, 50Ω impedance. 5V DC is supplied (maximum current of 50mA) to power an active antenna. The total combined gain of the antenna system (antenna plus cable and connectors) should fall in the range of 10 to 35 dB, the optimum being 22dB.

The TCG 1000P clock is normally supplied complete with a timing-optimised narrow-band antenna together with 15m of lead-in cable. (see [Appendix A](#) p16).

If required, the lead-in cable can be extended to 30m or 60m using the same type of cable without the need for any additional amplification. For lead-in lengths longer than 60m, either amplification and/or larger diameter, lower loss cable can be supplied to order.

A Lightning Protection device may be inserted into the antenna lead. A suitable device complete with additional cable connectors, a connector crimping tool and mounting hardware is available as an option (see [section 5.4](#) p12). Introduction of the Lightning protector does not degrade the performance of the antenna system.

Earth stud

An M4 bolt (to chassis) is provided for earthing of cable shields.

P7

A set of isolated changeover relay output via 3-pin plug-able connector – capable of switching up to 2A of AC/DC external load (230V AC). Wiring size is to 1.5mm², or to 1.0mm² on Rev-C and later units. Isolation is 2.5kV minimum.

4.2 Input/Output - Functions & Applications

Programmable outputs (P2, P3)

The outputs P2, P3 are each independently programmable to provide one of the following options.

- i) DCF-77 pulse simulation
- ii) Unmodulated (i.e. DC level-shift) IRIG-B (B00x)
- iii) Modified Manchester Modulated IRIG-B (B22x)
- iv) Programmed pulse sequence

In the case of option iv) above, separate settings are provided so that a differently programmed pulse sequence can be specified for each of the three outputs. Each of the three programmable outputs can also be inverted in its operation. Full details on configuring the programmable outputs are contained in [section 6.3](#) p14.

P7: Relay Output (“Sync” relay)

A set of changeover contacts is provided via a three-pin plug-able connector. This relay is active (“C” and “NO” connected) whenever the TCG 01 has established stable time sync from the GPS satellites. The active relay output indicates that all of the other output signals are operating within specification. On Rev-B and earlier units, P7 is a 3-way version of the P2 and P3 connectors, accommodating 1.5mm² cabling. The connector shown in [fig.2](#) accommodates 1mm² cabling. The sync relay can be configured to remain active (indicating “in sync”) for a period following the loss of satellite signals. The default period is one minute, but this can be factory set to a maximum period of 42:30 (2550 seconds).

4.3 Indicators & Display Unit

TCG 1000 has two LED indicators on the front panel.

SYN: This LED operates in parallel with the Sync Relay, and is active at all times when the unit is operating with time code outputs within specification. (i.e. time accurately tracking the GPS time signals)

GPS: Flashing cadences are used on this indicator to indicate the status of the GPS receiver (see [Section 3.1](#) p6 for details)

4.4 Power Requirements

P1: Power Input

Standard Power Supply is: DC: 12-36 Volts (AC: 15-24V RMS). Maximum power consumption is 6W. Connection is via the 2-pin plug connector **P1** on rear panel. The power input is *not* polarity-sensitive (despite the markings). The casing is isolated from the power supply inputs so that either (or neither) power supply polarity can be earthed to station earth.

20-72Volt DC, and 90-350 Volt DC power supply options are available as factory-fitted options. (See [Section 5.2](#) p11 for full details on power supply options) All power supply options have surge protection.

4.5 Isolation & Protection

All inputs and outputs feature 2.5kV isolation from each other. In addition, the logic level outputs (**P2** and **P3**) are each protected against damage from transverse voltage events via a three-stage network of varistor, auto-resetting fuse, and transient suppressor diode.

Fuse and varistor protection is removed when the switching MOSFET factory option is fitted. The user must provide an external power supply and suitable fusing to use the MOSFET output option. (See [Section 5.1](#) p11 for further information on the MOSFET Output option)

Varistor protection and current limiting (nominally 5mA) are employed for protection on the general-purpose input.

Transformer isolation via DC-DC converter is used for the main power supply and for power to each of the logic output-drive circuits. High-speed, fixed delay opto-isolators are used in each of the time-sensitive signalling paths. The isolation does not degrade the time accuracy of the output signals, as the fixed delays of the isolating components (together with the delay associated with the antenna lead-in) are all internally compensated.

4.6 Dimensions

Width 160mm
Depth 155mm
Height 40mm (1U)
Weight 0.9kg

Each TCG 1000 unit is normally supplied complete with antenna, antenna mount, antenna cable and 1U 19" rack-mount hardware. Shipping weight of the complete TCG 1000 kit is 4.5Kg.

4.7 Identification

Each TCG 1000 unit is shipped with an identification label on the base. The label provides details of the particular options fitted to the unit, the power supply requirement, and the serial number.

5 Factory Hardware Options

5.1 Opt1A, Opt1B - TCG 01 High Voltage Output Option

TCG 01 may be ordered with either or both of the **P2** and **P3** outputs configured with a high voltage FET switching transistor instead of the standard 5V logic output. When so fitted, each output can switch an external load of up to 300VA, with a maximum “on” current rating of 1A, and a maximum rated Voltage of 300V DC.

Order **Opt 1A** for HV FET on **P3**. Order **Opt 1B** for HV FET on **P2**

External wiring should be arranged so that the external high voltage supply line (up to 300V DC max) is connected, via a fuse, to the load. The return connection from the load is then wired to one terminal of the **P2(P3)** output, and the other terminal of the **P2(P3)** output is then wired to complete the circuit back to the other side of the power supply. Do not connect the high voltage supply to P2 or P3 unless the high voltage option is fitted – check the label on the base of the TCG 01 unit.

Important! *It is the user’s responsibility to provide adequate protection in the form of an external fuse to protect the external power supply, the TCG 01 output switch and the load.*
Note: At all times, the polarity of the P2 (P3) connections should be such that conventional current flow is into the “+” terminal and out of the “o” terminal – i.e. “+” is at higher positive potential than “o”.

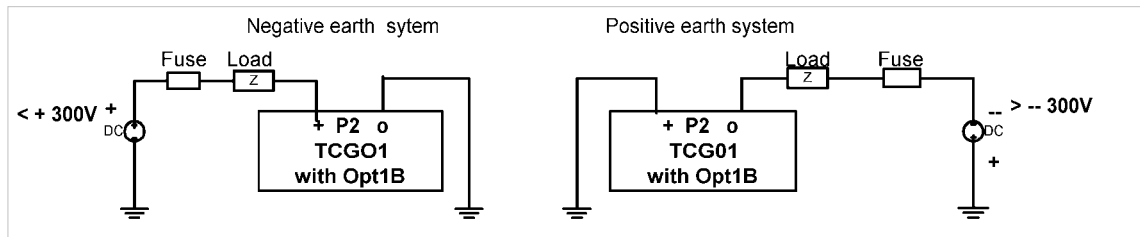

Fig 4 : High Voltage MOSFET Output Switch Option: Suggested wiring arrangements

Output isolation (from chassis and other I/O) is still maintained when the HV option is fitted. This simplifies the external load/supply arrangements, particularly when operating with positive-earth systems – as in many utility facilities.

5.2 Opt. 2M, Opt. 2H - Power Supply Options

There are three different power supply configurations that may be ordered with TCG 1000.

- a) Order **Standard Nominal 24Vdc**
 This supply operates with DC input in the range 12 –36Vdc,
 or with AC input in the range 16-24Vac
- b) Order **Opt.2M Nominal 48Vdc**
 This supply operates with DC input in the range 20-72Vdc,
 or with AC input in the range 24-48Vac
- c) Order **Opt 2H Nominal 110/250Vdc**
 This supply operates with DC input in the range 90-350Vdc,
 or with AC input in the range 80-240Vac

5.3 Opt 4 - Lightning Protection Kit

A lightning Protection kit is available for fitting into the antenna lead-in cable. The kit contains a protection device, two coaxial cable connectors, a connector crimp tool, and mounting hardware for the protection device. Full instructions relating to the installation and maintenance of the lightning protector are included with the kit, together with some guidelines as to best positioning of the antenna and protector unit to minimize the possibility of lightning-induced damage to the TCG 01 base unit.

Refer to [Appendix A.4](#) p19 for full details of the Antenna Lightning Protection Kit.

While the LP kit provides a high degree of protection, there is no guarantee of protection against a direct lightning strike to the antenna. Careful antenna positioning is strongly advised

5.4 P2 & P3 Output Connector Options

The connector options for outputs P2 and/or P3 are:

- 2 pin plug (up to 1.5mm² wire)
- BNC connector
- ST Fibre optic Tx (62.5/125um), 700m maximum fibre length

Refer to [section 4.1](#) p8 for a full description of the outputs.

6 Time Parameters

Time parameter set-up is carried out at the factory to customer specification.

6.1 Local Time Settings

Local Standard Time and Local Daylight Time offsets

The time offsets define the number of hours (and, in rare cases, minutes) that the local time differs from UTC time. A positive offset means that the local time is *ahead* of UTC. *If automatic Daylight Saving Time operation is not required, both of the offsets will be set to the same value.* For UTC operation, both values will be set to zero.

The TCG1000 Automatic Daylight savings changes can be based either on a fixed date, or a fixed rule for calculating a date that will be different depending on what year it is. Accurate information specifying the date and time that daylight savings “Starts” and “Ends” are required for correct observance.

6.2 General Options

Sync Hold Time

The “Sync Hold” parameter is used to control the time duration with no satellites visible that will be tolerated before TCG 01 will release the “sync” relay, and show loss of sync. TCG 1000’s antenna should be sited with a good view of the sky so that the unit normally tracks 4 or more satellites. In areas with poor GPS coverage there may be occasions where tracking is momentarily lost. The accuracy of TCG 1000’s outputs even when there is a complete satellite “blackout” is maintained to within a few micro-seconds over time periods of around a minute, and to within 200uS for up to 40 minutes. The presence of just one satellite signal is sufficient to reset output accuracy to within 1uS, and therefore reset the Sync Hold timeout. The factory default setting is 60 (1 minute delay).

In typical SCADA operations, time syncing to within 0.5mS is considered adequate, so setting the Sync Hold number to the maximum tolerance (representing 42.5 minutes) would be quite in order, as even in this worst case, TCG 01 performance is more than adequate. This may be a worthwhile strategy to minimise unnecessary “loss of sync” (relay drop-out) alarms when the sky view is very obstructed, or in extremely hostile electromagnetic environments

Mask Angle

This is the elevation above the horizon below which specific satellite signals will not be used in time and position calculations. The factory default value is 5 degrees. Range: 0-90.degrees.

Where the antenna view of the sky is severely restricted, in rare circumstances, altering this value may give some fine improvement in stability of the time signal. Increasing the angle reduces the likelihood of errors being introduced by multi-path signals from low elevation satellites (typically caused by reflections off land-based obstacles), but narrows the overall field of view.

Suppress Out of Sync Indications

This makes TCG 1000 operate as if it is in sync at all times, even if there is no antenna attached. The sync relay operation is unaffected by this option and will still indicate the true sync state of TCG 1000.

Suppress Outputs When Out of Sync

This option suppresses the TCG 1000’s output signals on P2, P3, P4, P5 and the Time Server when the clock goes out of sync. The sync relay operation is unaffected by this option and will still indicate the true sync state of TCG 1000.

6.3 Output Configuration

Programmable Outputs (P2 and P3)

Each of the two outputs (P2 & P3) can be programmed to give one of four different output waveforms.

The options available *independently* for each output are:

- i) DCF-77 output pulse simulation
- ii) IRIG-B NRZI (B000/B001 or B002/B003)
- iii) IRIG-B Modified Manchester Encoded (B220/B223 or B221/B222)
- iv) User Defined Pulse Sequence (separate definition stored for each output)

In the case of the User-Defined Pulse option being selected for any outputs, further parameters are entered to define the pulse sequence. A separate set of parameters is defined for each output specified to use a User Defined Pulse sequence. The parameters are as follows:

- a) Pulses output can be every “second”, “minute”, “hour”, or “day”.
- b) The number of pulses that will be produced in the selected time interval can also be specified. Selection is constrained to even divisors of the time interval. For example, if the time interval selected is per minute or per hour, then the “Pulses” parameter can be values 1, 2, 3, 4, 5, 6, 10, 12, 15, 20 or 30.
- c) The “Offset” data entry boxes specify how much time elapses into the defined time interval before pulsing starts.
- d) The “Duration” of individual pulses can also be set.

IRIG-B Options

Binary Seconds in IRIG-B.

The “Binary Seconds” field is an option specified by IRIG standard 200-98. If this option is selected, all of the outputs programmed for IRIG-B code will include the “Binary Seconds of Day” data.

IRIG-B Extensions.

IRIG Standard 200-98 specifies a 27-bit control field in the IRIG-B time codes, but does not define the content. There are now two standards defined for the use of these control bits. IEEE 1344 and AFNOR NF S87-500.

IEEE1344 Extensions (US origin)

The IEEE 1344 IRIG-B extensions define data for

- Year;
- Impending leap second info;
- Local time offset info;
- Impending daylight savings change info;
- Time-quality figure.

AFNOR S87-500 Extensions (European Origin)

The AFNOR NF S87-500 extensions define data for:

- day of year;
- day of week;
- year;
- month;
- day of month.

If either option is selected, *all* of the outputs programmed for IRIG-B code – including the amplitude- modulated output - will include the extension data in the control field.

Local/UTC Selection

UTC Time In DCF-77, IRIG-B

When selected, UTC time will be output in the time codes. Otherwise Local time using TCG 1000's current Local Standard Time and Daylight Savings Time settings will be output.

6.4 GPS Receiver

The internal GPS receiver will detect and 'tune in' to GPS satellites signals automatically so that even if a TCG 1000 unit has been previously installed 1000's of km away it should achieve 'sync' and hence output accurate time generally within 30 minutes to 2 hours as long as the GPS antenna has a good clear view of the sky.

The TCG 1000's internal GPS receiver will be factory pre-set to the shipping destination coordinates unless otherwise advised. This will ensure that the TCG 1000 unit achieves 'sync' and hence output accurate time as quickly as possible.

Appendix A – Antenna Details

A.1 Antenna Cable Specification

The TCG01 unit's standard shipping configuration includes 15 metres of cable factory-fitted with an N-type male connector at one end, and an SMA male connector at the other. The N-type connector mates with the connector on the included antenna and provides a robust and weather-resistant connection. The much smaller SMA connector mates with the connector on the TCG01 rear panel and is only fractionally larger in diameter than the cable itself. This facilitates installation in conduit and through small apertures.

The supplied cable has the following characteristics:

Centre conductor:	1.42mm diameter Solid bare copper
Dielectric:	3.81mm diameter Low loss, closed polyethylene foam (Cellular PE)
Shield:	3.94mm diameter Aluminium Laminated Tape bonded to the Dielectric, with a Tinned Copper Overbraid – 4.52mm diameter
Jacket:	6.10mm Black Polyethylene
Bending Radius:	40mm (maintaining less than 1 ohm impedance change at bend).
Weight:	0.051 kg/metre
Temperature Range:	-40°C to +85°C
Impedance:	50 ohms
Velocity:	84%
Capacitance:	79.4pf/metre
DC Resistance:	
- Centre conductor	10.5 ohms per 1000 metre
- Shield	12.8 ohms per 1000 metre
Attenuation:	0.33dB per metre @ 1575.42MHz (L1)
Shielding:	> 90dB
Phase Stability:	+/- 10ppm/degree C

This is a high performance RF cable, and care should be taken during installation to ensure that the minimum bending radius limit noted above is scrupulously maintained.

Optional cable lengths of 30m or 60m are also available.

While the cable shielding is excellent, the cable should not be routed in close proximity to power cables or other RF cables carrying transmitter signals. – in particular, parallel runs are to be avoided if possible. If such runs are absolutely unavoidable, a minimum separation of 30cm may be used as a guideline.

The GPS receiver embedded in TCG1000 has excellent OOB rejection characteristics, as does the antenna itself. However, sound engineering practice should not rely on these factors alone to guarantee performance. Careful installation will enhance the long-term reliability and on-going stability of the Time Code Generator.

A.2 Antenna Specification

The TCG1000 unit's standard shipping configuration includes an active GPS antenna specifically designed for industrial/static timing environments, together with a mounting bracket.

General Characteristics	Antenna Description	Active microstrip patch antenna Molded UV-resistant plastic conical radome Aluminium die cast bottom housing Electrically shielded low noise amplifier assembly
Performance Characteristics	Operating Frequency	L1 (1575.42 MHz, +/- 2MHz)
	Input Impedances	50 Ohm
	VSWR	1.5 (typical) @ 1575.42 MHz
	Bandwidth	25 MHz (typical +/- 3dB points) filtering is 40dB not 4dB at +/- 50MHz
Electrical Characteristics	Polarization	Right hand circular
	Azimuth Coverage	360°
	Elevation Coverage	0° to 90°
	Gain Characteristics of Antenna Element	+2.0 dBic minimum at zenith -10 dBic minimum at 0° elevation
	Filtering	4dB minimum @ +/- 50 MHz
	LNA Gain	25dB (typical)
	Noise Figure	< 1.5dB (typical)
Physical Characteristics	Dynamics	Vibration: SAE J1455
	Power Requirements	5 +/- 0.25 Vdc
	Power Consumption	26 mA @ 5 Vdc (typical)
Environmental Characteristics	Dimensions	102.0 diameter x 82.0 height (mm)
	Weight	312 grams
	Mount	Center mount M28 nut)
	Connector	N-Connector (jack style)
	Operating Temperature	-40°C to +85°C
	Storage Temperature	-40°C to +85°C
	Humidity	85% noncondensing +30°C to +60°C
	UV Radiation	JIS D0202 (Sunshine carbon Arc System)
	Salt Spray Test	Spray 5% NaCl solvent at +35°C
	Immersion Test	1 meter (with connector sealed)
Transient Voltage Test	+/- 12kV	

A.3 Antenna Mounting
Antenna Mount to a 1 inch Nominal Pipe

Figure below details the installation of the GPS antenna assembly to a 1 inch nominal pipe with the mounting bracket.

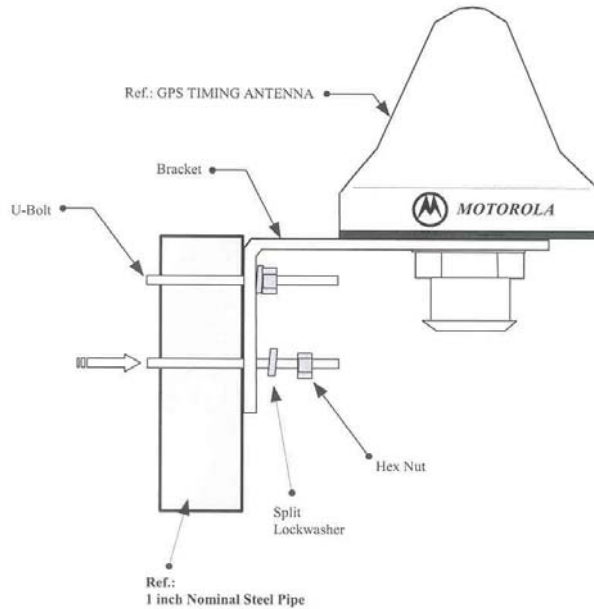

Extreme Weather and Environmental Conditions

To provide additional protection against extreme weather and environmental conditions, a plastic pipe tubing is recommended. This tubing should be secured to the mounting nut of the antenna assembly and should extend to the mating N-type cable plug. A product similar to Armaflex Pipe Insulation Tubing products is recommended. The figure below shows a pictorial overview of this recommendation.

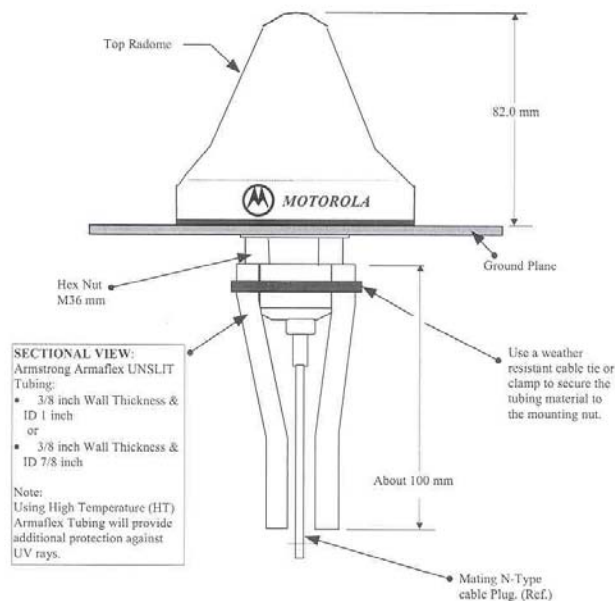

A.4 Antenna Lightning Protection Kit

LPK01 – Antenna Lightning Protection Kit - for use with TCG01 GPS- controlled Clock/Time Code Generator.

General

The GPS antenna supplied with TCG1000 meets standard IEC100-4-5 for lightning protection. However, this will not provide immunity from damage caused by either a direct lightning strike, or from voltages induced in the antenna lead-in cable due to side flashes or induction.

The first line of protection against the effects of lightning-induced surge events involves positioning the antenna in a “lightning-protected zone” as far as is possible. In practice, this means ensuring that there is at least one other earth-bonded structure located in the same rooftop area (e.g. another antenna, or a lightning rod) that reaches significantly higher than the top of the GPS antenna. The GPS Antenna should then be mounted so that it lies within a 45-degree angle from the top of the other earth-bonded structure. The GPS antenna mount itself should also be securely bonded directly to the building protection earth – and *not* connected via any of the other earthed structures.

All TCG1000 antenna installations should follow the guidelines above – regardless of whether a separate lightning protection device is to be fitted to the antenna lead-in cable.

In areas with a low incidence of electrical storms, careful attention to antenna positioning and earth connections may be all the protection deemed necessary.

The antenna lightning protection kit LPK01 affords additional security through the use of a gaseous discharge arrester cartridge mounted in an earthed casing. This assembly, known as an EMP protector, is installed in the antenna lead-in coax cable. In the event of a lightning-derived high voltage surge occurring on the coaxial cable, the discharge tube fires, short-circuiting the cable directly to the protection ground.

N.B. Although a correctly installed EMP Protector will provide enhanced security against lightning-derived damage to the TCG01 clock, there remains no absolute guarantee of full protection against all lightning-triggered surge events.

The performance of the TCG1000 antenna system under normal (non-surge) conditions is virtually unaffected by the introduction of a correctly installed EMP Protector.

LPK01 Kit Contents

- 1x Huber+Suhner EMP Protector type 3403.17.0023 (DC path maintained)
- 2x M4 Mounting bolts with nuts & serrated washers
- 2x N-type Male Crimp Style Coaxial cable connector set to match antenna cable
- 1x Crimp Tool to match the above connectors (RG59)
- 1x Roll Self-amalgamating Insulation tape

For the lightning protector to be effective, it must be firmly mounted to a conductive metal surface that is itself bonded to the building protective earth. **Please ensure that a good electrical connection is made between the surge protector and the earthing system.** The protector supplied features two mounting holes to accommodate M4 screws. The holes are on 24mm centres, one above the other (vertically orientated). The protector should be bolted to the plate so that the antenna connections are in the horizontal plane with the body of the protector below the antenna connection ports. When mounted correctly, the protector label should be readable directly, with the two M4 mounting screws and the additional earth connection stud on the left-hand side.

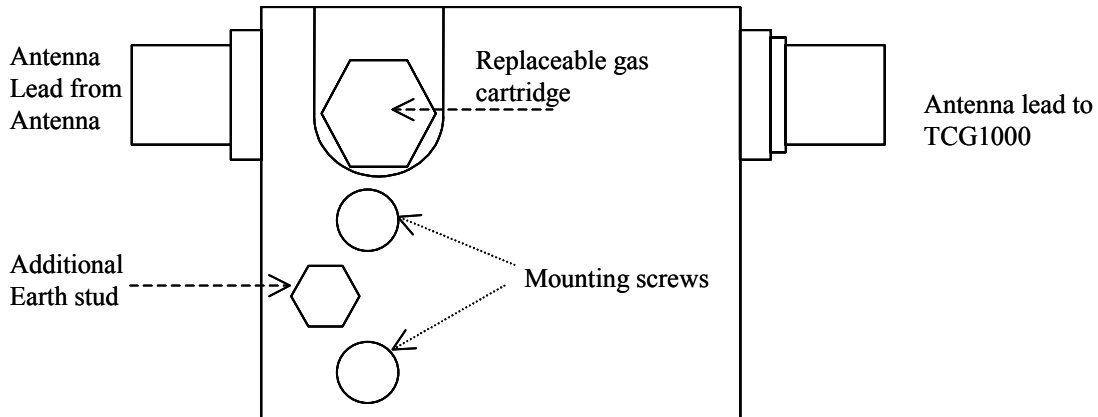

Note: Drawing is approximate only – not to scale.

All earthing connections should be as short as possible, should have no sharp bends or loops and should not be coiled to take up extra cable.

The preferred mounting position is on the *inside* of the building’s exterior wall, adjacent to the antenna lead entry point. In the event of a lightning strike, it is likely that the gas-discharge cartridge on the protector will need replacing. It is therefore necessary to ensure that the protector is mounted so that there is room to place a 14mm open-ended spanner on to the Gas Cartridge cover. Care should also be taken to ensure that the antenna lead is not bent through too tight a radius at either the entry or exit points to the protector.

The absolute minimum bend radius for the antenna cable supplied is 40mm, but it is preferable to use a larger bending radius if possible. One way of achieving this is by positioning the protector so that the incoming antenna lead comes through the wall about 150mm away from the protector’s connector. This provides some space to ease the incoming cable into a gentle arc back on to the connector.

The antenna cable must be cleanly cut at the appropriate point and the resulting two ends terminated with the N-type connectors provided. The connectors are then attached to the protector assembly and tightened firmly by hand. Seal each of the connections by stretch-wrapping them with the self-amalgamating tape supplied in the kit. The seal provides protection against any moisture ingress, and prevents the connections from loosening over time.

Care must be taken to mount the N-type connectors to the coax cable correctly according to the drawing attached (T00100B3300). As the GPS antenna operates at a frequency in excess of 1.5GHz, it is **essential** that the cable be prepared **exactly** as per the drawing (**Use Option 2 measurements shown** – all measurements in millimetres). A purpose-built Crimp tool is included in the kit to aid the process – use the RG59(0.255) die for the external hex housing.

Montagecode
B33XX
assembly code

Montageanweisung Assembly Instruction

Montagecode
B33XX
assembly code

Abisoliermaße *stripping instruction*

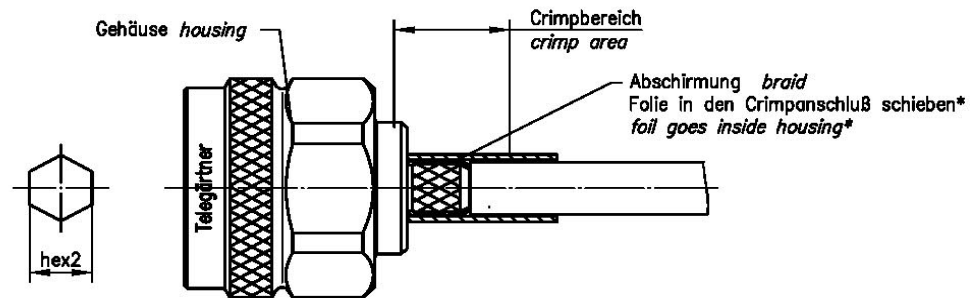
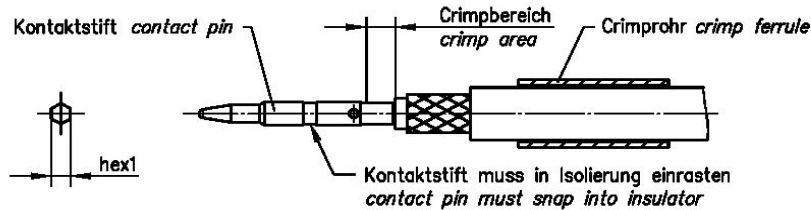
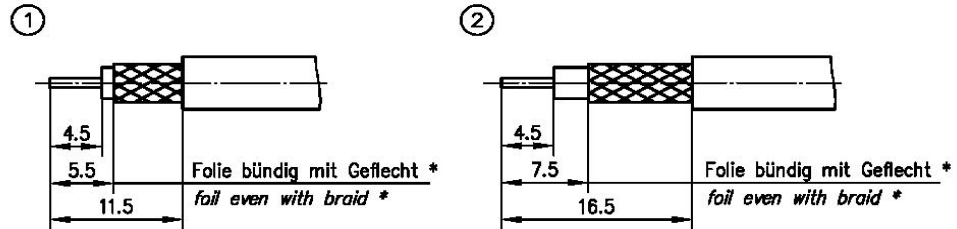

* nur für Kabel mit Folie / only for cables with foil

XX	Crimpeinsatz crimp insert	6kt.1 x Länge hex1 x length	6kt.2 x Länge hex2 x length	Abisoliermaße stripping instruction
05	N01001A0005	1.69x2.5	5.41x8	①
06	N01001A0007	1.69x2.5	6.48x8	②

				Datum date	Name name	Serie N crimp Series N crimp	
				Gez. drawn	29.09.00	HM	
Index index	Änderung modification	Datum date	Name name	Gepr. app'd	11.10.00	GJ	Unter- Art R
Original original	A4	Blatt sheet	1/1	Maßstab scale	2:1		TG-Nr. T00100B3300
				Ersatz für/replacement for			

Alle Rechte vorbehalten/All rights reserved © by Telegärtner K. Gärtnert GmbH D-71144 Steinenbronn Lärchenstr.35 Tel.:+49(0)7157/125-100 Fax:-120 URL: www.telegoertner.com

Disclaimer

TEKRON INSTRUMENTS disclaims any liability or responsibility for the results of improper or unsafe installation practice including, but not limited to, any excessive performance degradation of the TCG1000 antenna system resulting from incorrect field installation of coaxial cable connectors.

Warranty Statement

Tekron International Ltd (Tekron) warrants for a period of TWO years from the date of shipment that each Product supplied shall be free of defects in material and workmanship. During this period, if the customer experiences difficulty with a product and is unable to resolve the problem by phone with Tekron Technical Support, a Return Material Authorisation (RMA) will be issued. Following receipt of an RMA number, the customer is responsible for returning the product to Tekron, freight prepaid. Tekron, upon verification of warranty will, at its option, repair or replace the product in question and return it to the customer, freight prepaid. No services are handled at the customer's site under this warranty.

Tekron shall have no obligation to make repairs, or to cause replacement required through normal wear and tear or necessitated in whole or in part by catastrophe, fault or negligence of the user, improper or unauthorised use of the Product, or use of the Product in such a manner for which it was not designed, or by causes external to the Product, such as, but not limited to, power or failure of building services.

There are no understandings, agreements, representations or warranties, express or implied, including warranties of merchantability or fitness for a particular purpose, other than those specifically set out above or by any existing contract between the parties. Any such contract states the entire obligation of Tekron. The contents of this document shall not become part of or modify any prior or existing agreement, commitment or relationship.

The information, recommendation, description and safety notations in this or other documents supplied by Tekron are based on general industry experience and judgement with respect to such hardware and software. THIS INFORMATION SHOULD NOT BE CONSIDERED TO BE ALL INCLUSIVE OR COVERING ALL CONTINGENCIES. NO OTHER WARRANTIES, EXPRESS OR IMPLIED, INCLUDING WARRANTIES OF FITNESS FOR A PARTICULAR PURPOSE OR MERCHANTABILITY, OR WARRANTIES ARISING FROM COURSE OF DEALING OR USAGE OF TRADE, ARE MADE REGARDING THE INFORMATION, RECOMMENDATIONS, DESCRIPTIONS AND SAFETY NOTATIONS CONTAINED HEREBY AND IN HARDWARE AND SOFTWARE SPECIFICATION DOCUMENTATION, OR INSTRUCTIONS SUPPLIED BY Tekron. In no event will Tekron be responsible to the user in contract, in tort (including negligence), strict liability or otherwise for any special, indirect, incidental or consequential damage or loss of equipment, plant or power system, cost of capital, loss of profits or revenues, cost of replacement power, additional expenses in the use of existing software, hardware, equipment or facilities, or claims against the user by its employees or customers resulting from the use of the information, recommendations, descriptions and safety notations supplied by Tekron. Tekron liability is limited (at its election) to (1) refund of buyer's purchase price for such affected products (without interest); (2) repair of such products, or (3) replacement of such products, provided however, that the buyer follows the procedures set forth herein.

Warranty claims must be received by Tekron within the applicable warranty period. A replaced product, or part thereof, shall become the property of Tekron and shall be returned to Tekron at the Purchaser's expense.

A return material authorisation number issued by Tekron must accompany all return material.

NOTES

The information in this manual may change without notice. The manufacturer assumes no responsibility for any errors that may appear in this manual.

Ethernet is a trademark of XEROX Corporation. UNIX is a registered trademark of The Open Group. Windows 95, Windows 98, Windows 2000, Windows NT and Hyperterm are trademarks of Microsoft Corp. WinOncore12 and Oncore are trademarks of Motorola Inc.

Copyright 2003, Tekron International Ltd. All rights reserved. No part of the contents of this document may be transmitted or reproduced in any form or by any means without the written permission of Tekron International Ltd. Published in New Zealand.

WARNING

This product has been designed to comply with the limits for a Class A digital device pursuant to Part 15 of FCC rules. These limits are designed to provide reasonable protection against such interference when operating in a commercial environment.